

# STATISTICAL STABILITY FOR HÉNON MAPS OF THE BENEDICKS-CARLESON TYPE

JOSÉ F. ALVES, MARIA CARVALHO, AND JORGE MILHAZES FREITAS

ABSTRACT. We consider the family of Hénon maps in the plane and show that the SRB measures vary continuously in the weak\* topology within the set of Benedicks-Carleson parameters.

## CONTENTS

1. Introduction	1
2. Insight into the reasoning	3
3. Dynamics of Hénon maps on Benedicks-Carleson parameters	5
4. A horseshoe with positive measure	14
5. Proximity of critical sets	19
6. Proximity of leading Cantor sets	23
7. Proximity of stable curves	27
8. Proximity of $s$ -sublattices and return times	30
9. Statistical stability	40
References	52

## 1. INTRODUCTION

At the end of the 19th century, Poincaré addressed the problem of evolution and stability of the solar system, which led to many surprising questions and gave birth to the modern theory of dynamical systems as a qualitative study of the dynamics. The main goal of this theory is the description of the *typical behavior* of orbits, and the understanding of how this behavior changes when we perturb the system or to which extent it is robust. In the present work we are specially concerned with the problem of the *stability* of systems.

The first fundamental concept of robustness, *structural stability*, was formulated in the late 30's by Andronov and Pontryagin. It requires the persistence of the orbit topological structure under small perturbations, expressed in terms of the existence of a homeomorphism sending orbits of the initial system onto orbits of the perturbed one. This concept

---

*Date:* October 29, 2009.

*2000 Mathematics Subject Classification.* 37C40, 37C75, 37D25.

*Key words and phrases.* Hénon attractor, SRB measure, statistical stability.

Work partially supported by FCT through CMUP and POCI/MAT/61237/2004.

is tied with the notion of *uniform hyperbolicity* introduced by Smale in the mid 60's. A stronger connection was conjectured by Palis and Smale in 1970: a diffeomorphism is structurally stable if and only if it is uniformly hyperbolic and satisfies the so-called transversality condition. During this decade the “if” part of the conjecture was solved due to the contributions of Robbin, de Melo and Robinson; in the 80's Mañé settled the  $C^1$ -stability conjecture. The flow case was solved by Aoki and Hayashi, independently, in the 90's, also in the  $C^1$ -topology.

In spite of these astonishing successes, structural stability proved to be somewhat restrictive. Several important models, such as Lorenz flows, Hénon maps and other non-uniformly hyperbolic systems fail to present structural stability, although some key aspects of a statistical nature persist after small perturbations. The contributions of Kolmogorov, Sinai, Ruelle, Bowen, Oseledets, Pesin, Katok, Mañé and many others turned the attention of the study of dynamical systems from a topological perspective to a more statistical approach, and Ergodic Theory experienced an unprecedented development. In trying to capture this statistical persistence of phenomena, Alves and Viana [AV02] proposed the notion of *statistical stability*, which expresses the continuous variation of physical measures as a function of the evolution law governing the systems. A *physical measure* for a smooth map  $f : M \rightarrow M$  on a manifold  $M$  is a Borel probability measure  $\mu$  on  $M$  for which there is a positive Lebesgue measure set of points  $x \in M$ , whose union forms the *basin* of  $\mu$ , such that

$$\lim_{n \rightarrow \infty} \frac{1}{n} \sum_{j=0}^{n-1} \varphi(f^j(x)) = \int \varphi d\mu, \quad (1.1)$$

for any continuous function  $\varphi : M \rightarrow \mathbb{R}$ . Physical measures are intimately connected with *Sinai-Ruelle-Bowen measures* (SRB for short). An  $f$ -invariant Borel probability measure  $\mu$  is said to be SRB if it has a positive Lyapunov exponent and the conditional measures of  $\mu$  on unstable leaves are absolutely continuous with respect to the Riemannian measure induced on those leaves; see Section 3.8 for a precise definition. The existence of SRB measures for general dynamical systems is usually a difficult problem. However, Sinai, Ruelle and Bowen established the existence of SRB measures for Axiom A attractors which qualify as physical measures. Moreover, Axiom A diffeomorphisms are statistically stable.

The existence of SRB measures for a large set of one-dimensional quadratic maps exhibiting non-uniformly expanding behavior has been established in the pioneer paper of Jakobson [Ja81]. Additionally, the work of Collet-Eckmann [CE80a, CE80b, CE83] and Benedicks-Carleson [BC85] became a major breakthrough in that direction and allowed a well succeeded approach to higher dimensional maps. A key ingredient is the exponential growth of the derivative along the critical orbit for a positive Lebesgue measure set  $\mathcal{BC}_1$  of parameters. Regarding statistical stability, Freitas [Fr05] showed that the SRB measures vary continuously within the parameter set  $\mathcal{BC}_1$ ; see also [Ts96] and [RS97] where Tsujii, Rychlik and Sorets obtained related results. Notice that, by the work of Thunberg [Th01], one cannot expect statistical stability on the whole set of parameters for the quadratic family.

Hénon [He76] proposed the two-parameter family of maps

$$f_{a,b} : \mathbb{R}^2 \longrightarrow \mathbb{R}^2 \\ (x, y) \longmapsto (1 - ax^2 + y, bx)$$

as a model for non-linear two-dimensional dynamical systems, which can be thought as a simplified discrete version of the Lorenz flow. Based on numerical experiments for the parameters  $a = 1.4$  and  $b = 0.3$ , Hénon conjectured that this dynamical system should have a *strange attractor*. In principle, most initial points could be attracted to a periodic cycle, so it was not at all *a priori* clear that the attractor detected by Hénon in his experiments was not a long stable periodic orbit. However, Benedicks and Carleson [BC91] managed to prove that Hénon's conjecture was true for small  $b > 0$ , showing that for a positive Lebesgue measure set  $\mathcal{BC}$  the map  $f_{a,b}$  with  $(a, b) \in \mathcal{BC}$  exhibits a *non-hyperbolic attractor*. Afterwards, Benedicks and Young [BY93] proved that each of these non-hyperbolic attractors supports a unique SRB measure  $\nu_{a,b}$ , which is also a physical measure and whose main statistical features were studied by Benedicks, Viana and Young in [BV01, BV06, BY00]. Thus, a natural question is: are the Hénon maps of the Benedicks-Carleson type statistically stable? The main result of this work gives a positive answer to this question.

**Theorem A.** *The map which associates to each  $(a, b) \in \mathcal{BC}$  the SRB measure  $\nu_{a,b}$  is continuous with respect to the weak\* topology in the space of probability measures.*

Despite being metrically robust, the strange attractors appearing for the Benedicks-Carleson parameters are very fragile. In fact, Ures [Ur95] showed that the Benedicks-Carleson parameters can be approximated by other parameters for which the Hénon map has a homoclinic tangency associated to a fixed point. Hence, according to Newhouse's results [Ne74, Ne79], one may deduce the appearance of infinitely many attractors in the neighborhood of the Hénon attractor. Moreover, Ures [Ur96] proved that the SRB measures  $\nu_{a,b}$  corresponding to  $(a, b) \in \mathcal{BC}$  can be approximated by Dirac measures supported on sinks. Nevertheless, Benedicks and Viana [BV06] showed that the Hénon maps in  $\mathcal{BC}$  are *stochastically stable*. This notion was introduced by Kolmogorov and Sinai in the 70's and in broad terms asserts that time-averages of continuous functions are only slightly affected when iteration by the dynamics is perturbed by a small random noise. Stochastic stability may imply statistical stability if we allow a deterministic noise. However, the proof of the stochastic stability in [BV06] uses strongly the absolute continuity of the random noise, which prevents us to deduce the statistical stability from the stochastic one.

## 2. INSIGHT INTO THE REASONING

We consider a sequence of parameters  $(a_n, b_n)_{n \in \mathbb{N}} \in \mathcal{BC}$  converging to  $(a_0, b_0) \in \mathcal{BC}$ . Let  $(\nu_n)_{n \in \mathbb{N}}$  and  $\nu_0$  denote the respective SRB measures. Our goal is to show that  $\nu_n$  converges to  $\nu_0$  in the weak\* topology. We prove this by showing that every subsequence  $(\nu_{n_i})_{i \in \mathbb{N}}$  contains a subsequence convergent to  $\nu_0$ . Let us give some details on how to find this convergent subsequence.

The main problem we have to overcome is the need of comparing measures supported on different attractors. Our strategy is to look for a common ground where the construction of the SRB measure for every parameter is rooted. To do so, we start by noting that each of these maps admits a horseshoe  $\Lambda_{a,b}$  with infinitely many branches and variable return times (we will drop the indices when we refer to properties that apply to all these objects) obtained by intersecting two transversal families of local stable and unstable curves. Besides,  $\Lambda$  intersects each local unstable curve in a positive Lebesgue measure Cantor set, and for each  $z \in \Lambda$  it is possible to assign a positive integer  $R(z)$  defining the return time function  $R : \Lambda \rightarrow \mathbb{N}$  which indicates that  $z$  returns to  $\Lambda$  after  $R(z)$  iterates. The hyperbolic properties of  $\Lambda$  and the good behavior of  $R$  allow us to build a Markov extension that organizes the dynamics of these Hénon maps. Thus, one needs to show first that for nearby parameters the corresponding horseshoes are also close. We remark that for each parameter there is not a unique horseshoe with the required properties. Therefore, what we can establish is that for a given parameter  $(a, b)$  and a chosen horseshoe  $\Lambda_{a,b}$ , if we consider a small perturbation  $(a', b')$ , then it is possible to build a horseshoe  $\Lambda_{a',b'}$  with the desired hyperbolic properties and which is close to  $\Lambda_{a,b}$ .

These horseshoes play an important role in a construction of the SRB measures that suits our purposes. Actually,  $f^R : \Lambda \rightarrow \Lambda$  preserves a measure  $\tilde{\nu}$  with absolutely continuous conditional measures on local unstable curves with respect to the Lebesgue measure on each curve; the good behavior of the function  $R$  ensures that the saturation of  $\tilde{\nu}$  is an SRB measure, and by uniqueness it follows that the saturation of  $\tilde{\nu}$  is the SRB measure. To prove the continuous dependence of these SRB measures on the parameter,  $\Lambda$  is collapsed along stable curves yielding a quotient space  $\bar{\Lambda}$ , which can be thought inside a fixed local unstable curve  $\hat{\gamma}^u$ , and whose elements are represented by the intersection of the corresponding stable curve with  $\hat{\gamma}^u$ . This way our task is reduced to analyze  $\bar{f}^R : \bar{\Lambda} \rightarrow \bar{\Lambda}$ . This map is piecewise uniformly expanding and its Perron-Frobenius operator has a spectral gap under the usual aperiodicity conditions; so there is an  $\bar{f}^R$ -invariant density with respect to Lebesgue measure on  $\hat{\gamma}^u$ . As  $\hat{\gamma}^u$  is nearly horizontal, we can think of  $\bar{\rho}$  as a function defined on a subset of the  $x$ -axis. The advantage of this perspective is that it gives us the desired common domain for these densities, providing the first step in the verification of the continuity.

Therefore, the steps for the construction of the convergent subsequence are the following:

- Fix a parameter  $(a_0, b_0) \in \mathcal{BC}$  and a respective horseshoe  $\Lambda_0$ .
- Pick any sequence of parameters  $(a_n, b_n) \in \mathcal{BC}$  such that  $(a_n, b_n) \rightarrow (a_0, b_0)$  as  $n \rightarrow \infty$  and consider  $f_n = f_{a_n, b_n}$  for all  $n \in \mathbb{N}_0$ .
- Construct for every  $n \in \mathbb{N}$  a horseshoe  $\Lambda_n$  adequate to  $f_n$  and such that it gets closer to  $\Lambda_0$  as  $n \rightarrow \infty$ .
- Collapse  $\Lambda_n$  and consider the  $\bar{f}_n^R$ -invariant densities  $\bar{\rho}_n$ . Realize them as functions defined on an interval of the  $x$ -axis and belonging to a closed disk of  $L^\infty$ . Apply Banach-Alaoglu Theorem to derive a convergent subsequence  $\bar{\rho}_{n_i} \rightarrow \bar{\rho}_\infty$ .

- Employ a technique used by Bowen in [Bo75] to lift the  $\overline{f^R}$ -invariant measure from the quotient space  $\bar{\Lambda}$  to an  $f^R$ -invariant measure on the horseshoe  $\Lambda$ . This way we obtain measures  $\tilde{\nu}_{n_i}$  and  $\tilde{\nu}_\infty$ , defined on  $\Lambda_{n_i}$  and  $\Lambda_0$ , respectively.
- Verify that all the measures  $\tilde{\nu}_{n_i}$  and  $\tilde{\nu}_\infty$  disintegrate into conditional absolutely continuous measures on unstable leaves.
- Saturate the measures  $\tilde{\nu}_{n_i}$  and  $\tilde{\nu}_\infty$ . These saturations are  $f_{n_i}$ -invariant and  $f_0$ -invariant, respectively, and have absolutely continuous conditional measures on unstable leaves. The uniqueness of the SRB measures ensures that the saturation of  $\tilde{\nu}_{n_i}$  is  $\nu_{n_i}$  (the  $f_{n_i}$ -invariant SRB measure) and that of  $\tilde{\nu}_\infty$  is  $\nu_0$  (the  $f_0$ -invariant SRB measure).
- Finally, show that this construction yields  $\nu_{n_i} \rightarrow \nu_0$  in the weak\* topology.

### 3. DYNAMICS OF HÉNON MAPS ON BENEDICKS-CARLESON PARAMETERS

In this section we provide information regarding the dynamical properties of the Hénon maps  $f = f_{a,b}$ , corresponding to the Benedicks-Carleson parameters  $(a, b) \in \mathcal{BC}$ . We do not intend to give an exhaustive description but rather a brief summary of the most relevant features whose main ideas are scattered through the papers [BC91, BY93, MV93, BY00]. We recommend the summary in [BY93] and Chapter 4 of [BDV05] where the reader can find a comprehensive description of the techniques and results regarding Hénon-like maps, including a revision of the referred papers; both texts inspired our summary. The survey [LV03] provides a deep discussion about the exclusion of parameters which are the basis of Benedicks-Carleson results. Concerning the 1-dimensional case we also refer the paper [Fr05] in which a description of the Benedicks-Carleson techniques in the phase space setting can be found.

**3.1. One-dimensional model.** The pioneer work of Jakobson [Ja81] establishing the existence of a positive Lebesgue measure set of parameters where the logistic family presents chaotic behavior paved the way for a better understanding of the dynamics beyond the non-hyperbolic case. The analysis of the Hénon maps made by Benedicks and Carleson, triggered by the work of Collet-Eckmann [CE80a, CE80b] and Benedicks-Carleson [BC85] themselves, was a major breakthrough in that direction. A key idea is the exponential growth of the derivative along the critical orbit, introduced in [CE83]. In their remarkable paper [BC91], Benedicks and Carleson manage to establish, in a very creative fashion, a parallelism between the estimates for the 1-dimensional quadratic maps and the Hénon maps. This connection supports the use of 1-dimensional language in the present paper and compels us to remind the results in Section 2 of [BC91]. In there, it is proved the existence of a positive Lebesgue measure set of parameters, say  $\mathcal{BC}_1$ , within the family  $f_a : [-1, 1] \rightarrow [-1, 1]$ , given by  $f_a(x) = 1 - ax^2$  verifying

- (1) there is  $c > 0$  ( $c \approx \log 2$ ) such that  $|Df_a^n(f_a(0))| \geq e^{cn}$  for all  $n \geq 0$ ;
- (2) there is a small  $\alpha > 0$  such that  $|f_a^n(0)| \geq e^{-\alpha n}$  for all  $n \geq 1$ .

The idea, roughly speaking, is that while the orbit of the critical point is outside a critical region we have expansion (see Subsection 3.1.1); when it returns we have a serious setback

in the expansion but then, by continuity, the orbit repeats its early history regaining expansion on account of (1). To arrange for (1) one has to guarantee that the losses at the returns are not too drastic hence, by parameter elimination, (2) is imposed. The argument is mounted in a very intricate induction scheme that guarantees both the conditions for the parameters that survive the exclusions.

We focus on the maps corresponding to Benedicks-Carleson parameters and study the growth of  $Df_a^n(x)$  for  $x \in [-1, 1]$  and  $a \in \mathcal{BC}_1$ . For that matter we split the orbit in free periods and bound periods. During the former we are certain that the orbit never visits the critical region. The latter begin when the orbit returns to the critical region and initiates a bound to the critical point, accompanying its early iterates. We describe the behavior of the derivative during these periods in Subsections 3.1.1 and 3.1.2.

The critical region is the interval  $(-\delta, \delta)$ , where  $\delta = e^{-\Delta} > 0$  is chosen small but much larger than  $2 - a$ . This region is partitioned into the intervals

$$(-\delta, \delta) = \bigcup_{m \geq \Delta} I_m,$$

where  $I_m = (e^{-(m+1)}, e^{-m}]$  for  $m > 0$  and  $I_{-m} = -I_m$  for  $m < 0$ ; then each  $I_m$  is further subdivided into  $m^2$  intervals  $\{I_{m,j}\}$  of equal length inducing the partition  $\mathcal{P}$  of  $[-1, 1]$  into

$$[-1, -\delta) \cup \bigcup_{m,j} I_{m,j} \cup (-\delta, 1]. \quad (3.1)$$

Given  $J \in \mathcal{P}$ , we let  $nJ$  denote the interval  $n$  times the length of  $J$  centered at  $J$ .

3.1.1. *Expansion outside the critical region.* There is  $c_0 > 0$  and  $M_0 \in \mathbb{N}$  such that

- (1) If  $x, \dots, f_a^{k-1}(x) \notin (-\delta, \delta)$  and  $k \geq M_0$ , then  $|Df_a^k(x)| \geq e^{c_0 k}$ ;
- (2) If  $x, \dots, f_a^{k-1}(x) \notin (-\delta, \delta)$  and  $f_a^k(x) \in (-\delta, \delta)$ , then  $|Df_a^k(x)| \geq e^{c_0 k}$ ;
- (3) If  $x, \dots, f_a^{k-1}(x) \notin (-\delta, \delta)$ , then  $|Df_a^k(x)| \geq \delta e^{c_0 k}$ .

3.1.2. *Bound period definition and properties.* Let  $\beta = 14\alpha$ . For  $x \in (-\delta, \delta)$  define  $p(x)$  to be the largest integer  $p$  such that

$$|f_a^k(x) - f_a^k(0)| < e^{-\beta k}, \quad \forall k < p. \quad (3.2)$$

Then

- (1)  $\frac{1}{2}|m| \leq p(x) \leq 3|m|$ , for each  $x \in I_m$ ;
- (2)  $|Df_a^p(x)| \geq e^{c'p}$ , where  $c' = \frac{1-4\beta}{3} > 0$ .

The orbit of  $x$  is said to be bound to the critical point during the period  $0 \leq k < p$ . We may assume that  $p$  is constant on each  $I_{m,j}$ .

3.1.3. *Distortion of the derivative.* The partition  $\mathcal{P}$  is designed so that if  $\omega \subset [-1, 1]$  is such that, for all  $k < n$ ,  $f^k(\omega) \subset 3J$  for some  $J \in \mathcal{P}$ , then there exists a constant  $C$  independent of  $\omega$ ,  $n$  and the parameter so that for every  $x, y \in \omega$ ,

$$\frac{|Df_a^n(x)|}{|Df_a^n(y)|} \leq C.$$

3.1.4. *Derivative estimate.* Suppose that

$$|f_a^j(x)| \geq \delta e^{-\alpha j}, \quad \forall j < n. \quad (3.3)$$

Then there is a constant  $c_2 > 0$  such that

$$|Df_a^n(x)| \geq \delta e^{c_2 n}. \quad (3.4)$$

A proof of this fact can be found in [Fr05, Section 3] where it is also shown that there is  $\kappa > 0$  such that

$$|\{x \in [-1, 1] : |f_a^j(x)| \geq e^{-\alpha j}, \forall j < n\}| \geq 2 - \text{const } e^{-\kappa n}.$$

As an easy consequence, it is deduced that Lebesgue almost every  $x$  has a positive Lyapunov exponent. Moreover, we have a positive Lebesgue measure set of points  $x \in [-1, 1]$  satisfying (3.3), and so (3.4), for all  $n \in \mathbb{N}$ .

**3.2. General description of the Hénon attractor.** The following facts are elementary for  $f = f_{a,b}$  with  $(a, b)$  inside an open set of parameters.

Each  $f$  has a unique fixed point in the first quadrant  $z^* \approx (\frac{1}{2}, \frac{1}{2}b)$ . This fixed point is hyperbolic with an expanding direction presenting a slope of order  $-b/2$  and a contractive direction with a slope of approximately 2. The respective eigenvalues are approximately  $-2$  and  $b/2$ . In [BC91] it is shown that if we choose  $a_0 < a_1 < 2$  with  $a_0$  sufficiently near 2, then there exists  $b_0$  sufficiently small when compared to  $2 - a_0$  such that for all  $(a, b) \in [a_0, a_1] \times (0, b_0]$ , the unstable manifold of  $z^*$ , say  $W$ , never leaves a bounded region. Moreover, its closure  $\overline{W}$  is an attractor in the sense that there is an open neighborhood  $U$  of  $\overline{W}$  such that for every  $z \in U$  we have  $f^n(z) \rightarrow \overline{W}$  as  $n \rightarrow \infty$ .

3.2.1. *Hyperbolicity outside the critical region.* Let  $\delta$  be at least as small as in our 1-dimensional analysis and assume that  $b_0 \ll 2 - a_0 \ll \delta$ . The critical region is now  $(-\delta, \delta) \times \mathbb{R}$ . A simple calculation shows that outside the critical region  $Df$  preserves the cones  $\{|s(v)| \leq \delta\}$  (see [BY93] Subsection 1.2.3), where  $s(v)$  denotes the slope of the vector  $v$ . For  $z = (x, y) \notin (-\delta, \delta) \times \mathbb{R}$  and a unit vector  $v$  with  $s(v) \leq \delta$ , we have essentially the same estimates as in 1-dimension. That is, there is  $c_0 > 0$  and  $M_0 \in \mathbb{N}$  such that

- (1) If  $z, \dots, f^{k-1}(z) \notin (-\delta, \delta) \times \mathbb{R}$  and  $k \geq M_0$  then  $|Df^k(z)v| \geq e^{c_0 k}$ ;
- (2) If  $z, \dots, f^{k-1}(z) \notin (-\delta, \delta) \times \mathbb{R}$  and  $f^k(z) \in (-\delta, \delta) \times \mathbb{R}$  then  $|Df^k(z)v| \geq e^{c_0 k}$ ;
- (3) If  $z, \dots, f^{k-1}(z) \notin (-\delta, \delta) \times \mathbb{R}$  then  $|Df^k(z)v| \geq \delta e^{c_0 k}$ .

**3.3. The contractive vector field.** For  $A \in \text{GL}(2, \mathbb{R})$  and a unit vector  $v$ , if  $v \mapsto |Av|$  is not constant, let  $e(A)$  denote the unit vector maximally contracted by  $A$ . We will write  $e_n(z) := e(Df^n(z))$  whenever it makes sense. Observe that if we have some sort of expansion in  $z$ , say  $|Df^n(z)v| > 1$  for some vector  $v$ , then  $e_n(z)$  is defined and  $|Df^n(z)e_n(z)| \leq b^n$  since  $\det(Df^n(z)) = (-b)^n$ .

The following general perturbation lemma is stated in [BY00] and clarifies the assertions of Lemma 5.5 and Corollary 5.7 in [BC91], where the proofs can be found. Given  $A_1, A_2, \dots$ , we write  $A^n := A_n \dots A_1$ ; all the matrices below are assumed to have determinant equal to  $b$ .

**Lemma 3.1** (Matrix Perturbation Lemma). *Given  $\kappa \gg b$ , exists  $\lambda$  with  $b \ll \lambda < \min(1, \kappa)$  such that if  $A_1 \dots, A_n, A'_1 \dots, A'_n \in GL(2, \mathbb{R})$  and  $v \in \mathbb{R}^2$  satisfy*

$$|A^i v| \geq \kappa^i \quad \text{and} \quad \|A_i - A'_i\| < \lambda^i \quad \forall i \leq n,$$

then we have, for all  $i \leq n$ :

- $|A^i v| \geq \frac{1}{2} \kappa^i$ ;
- $\angle(A^i v, A'^i v) \leq \lambda^{\frac{i}{4}}$ .

From the Matrix Perturbation Lemma, it follows that if for some  $\kappa$  and  $v$ , we have  $|Df^j(z_0)v| \geq \kappa^j$  for all  $j \in \{0, \dots, n\}$ , then there is a ball of radius  $(\lambda/5)^n$  about  $z_0$  on which  $e_n$  is defined and  $|Df^n e_n| \leq 2(b/\kappa)^n$ . Assuming that  $\kappa$  is fixed and  $e_n$  is defined in a ball  $B_n$  around  $z_0$  the following facts hold (see [BC91, Section 5], [BY93, Section 1.3.4] or [BY00, Section 1.5]):

- (1)  $e_1$  is defined everywhere and has slope equal to  $2ax + \mathcal{O}(b)$ ;
- (2) there is a constant  $C > 0$  such that for all  $z_1, z_2 \in B_n$ ,

$$|e_n(z_1) - e_n(z_2)| \leq C|z_1 - z_2|;$$

- (3) for  $z_1 = (x_1, y_1), z_2 = (x_2, y_2) \in B_n$  with  $|y_1 - y_2| \leq |x_1 - x_2|$

$$|e_n(z_1) - e_n(z_2)| = (2a + \mathcal{O}(b))|x_1 - x_2|;$$

- (4) for  $m < n$ ,  $|e_n - e_m| \leq \mathcal{O}(b^m)$  on  $B_n$ .

From this point onward we restrict ourselves to the Hénon maps of the Benedicks-Carleson type, that is, we are considering  $f = f_{a,b}$  for  $(a, b) \in \mathcal{BC}$ .

**3.4. Critical points.** The cornerstone of Benedicks-Carleson strategy is the critical set in  $W$  denoted by  $\mathcal{C}$ , that plays the role of the critical point 0 in the 1-dimensional model. The critical points correspond to homoclinic tangencies of Pesin stable and unstable manifolds. For  $z \in W$ , let  $\tau(z) \in T_z \mathbb{R}^2$  denote a unit vector tangent to  $W$  at  $z$ . For each  $\zeta \in \mathcal{C}$ , the vector  $\tau(\zeta)$  is contracted by both forward and backward iterates of the derivative. In fact, we have  $\lim_{n \rightarrow \infty} e_n(\zeta) = \tau(\zeta)$ , which can be thought as the moral equivalent to  $Df(0) = 0$  in 1-dimension. The following subsections refer to [BC91], mostly Sections 5 and 6 (see also [BY93, Section 1.3.1]).

**3.4.1. Rules for the construction of the critical set.** The critical set  $\mathcal{C}$  is located in  $W \cap (-10b, 10b) \times \mathbb{R}$ . There is a unique  $z_0 \in \mathcal{C}$  on the roughly horizontal segment of  $W$  containing the fixed point  $z^*$ . The part of  $W$  between  $f^2(z_0)$  and  $f(z_0)$  is denoted by  $W_1$  and called the leaf of generation 1. Leaves of generation  $g \geq 2$  are defined by  $W_g := f^{g-1}W_1 \setminus \bigcup_{j \leq g-1} W_j$ . We assume that  $(a, b)$  is sufficiently near  $(2, 0)$  so that  $\bigcup_{g \leq 27} W_g$  consists of  $2^{26}$  roughly horizontal segments linked by sharp turns near  $x = \pm 1, y = 0$ , and that  $\bigcup_{g \leq 27} W_g \cap (-\delta, \delta) \times \mathbb{R}$  consists of  $2^{26}$  curves whose slope and curvature are  $\leq 10b$  – in [BC91] such a curve is called  $C^2(b)$ . In each of them there is a unique critical point

For  $g > 27$ , assume that all critical points of generation  $\leq g - 1$  are already defined. Consider a maximal piece of  $C^2(b)$  curve  $\gamma \subset W_g$ . If  $\gamma$  contains a segment of length  $2\rho^g$  centered at  $z = (x, y)$ , where  $\rho$  verifies  $b \ll \rho \ll e^{-72}$ , and there is a critical point  $\tilde{z} = (\tilde{x}, \tilde{y})$



of generation  $\leq g-1$  with  $x = \tilde{x}$  and  $|y - \tilde{y}| \leq b^{g/540}$ , then a unique critical point  $z_0 \in \mathcal{C} \cap \gamma$  of generation  $g$  is created satisfying the condition  $|z_0 - z| \leq |y - \tilde{y}|^{1/2}$ . These are the only critical points of generation  $g$ .

Observe that the exact position of a critical point is inaccessible since its definition depends on the limiting relation  $\lim_{n \rightarrow \infty} e_n(\zeta) = \tau(\zeta)$ . So the strategy in [BC91] is to produce approximate critical points  $\zeta^n$  of increasing order which are solutions of the equation  $e_n(z) = \tau(z)$ . Once an approximate critical point is born, parameters are excluded to ensure that a critical point  $\zeta \in \mathcal{C}$  is created nearby. Moreover,  $|\zeta^n - \zeta| = \mathcal{O}(b^n)$ .

**3.4.2. Dynamical properties of the critical set.** The parameter exclusion procedure leading to  $\mathcal{BC}$  is designed so that every  $z \in \mathcal{C}$  has the following properties:

- there is  $c \approx \log 2$  and  $C$  independent of  $b$  such that for all  $n \in \mathbb{N}_0$ ,

$$|Df^n(z) \begin{pmatrix} 0 \\ 1 \end{pmatrix}| \geq e^{cn} \quad \text{and} \quad |Df^n(z)\tau| \leq (Cb)^n; \quad (UH)$$

- there is a small number  $\alpha > 0$ , say  $\alpha = 10^{-6}$ , such that for all  $n \in \mathbb{N}$

$$\text{dist}(f^n(z), \mathcal{C}) \geq e^{-\alpha n}. \quad (BA)$$

The precise meaning of “dist” in the last equation will be described in Section 3.5.1. The uniform hyperbolicity expressed in  $(UH)$  is analogous to condition (1) in Subsection 3.1 while the basic assumption stated in  $(BA)$  is the surface analogue to condition (2) of the 1-dimensional model.

One of the reasons why the Benedicks-Carleson proof is so involved is that in order to  $e_n$  be defined in the vicinity of critical points, one has to require some amount of hyperbolicity which is exactly what one wants to achieve (see  $(UH)$  above). This difficulty is overcome by working with finite time approximations and imposing slow recurrence in a very intricate induction scheme. Once an approximate critical point  $\zeta^n$  of order  $n$  is designated one studies its orbit. When it comes near  $\mathcal{C}$ , there is a near-interchange of stable and unstable directions – hence a setback in hyperbolicity. But then the orbit of  $\zeta^n$  follows for some time the orbit of some  $\tilde{\zeta} \in \mathcal{C}$  of earlier generation and regains hyperbolicity on account of  $(UH)$  for  $\tilde{\zeta}$ . To arrange  $(UH)$  at time  $n+1$  for  $\zeta^n$ , it is necessary to keep the orbits from switching stable and unstable directions too fast, so by parameter exclusion we impose  $(BA)$ . At this stage it is possible to define  $e_{n+1}$  and thus find a critical point approximation of order  $n+1$ , denoted by  $\zeta^{n+1}$ . The information is updated and the process is repeated. Fortunately, a positive Lebesgue measure set of parameters survives the exclusions.

**3.5. Binding to critical points.** The critical point 0 in the 1-dimensional context plays a dual role. Firstly, the distance to the critical point is a measure of the norm of the derivative, which is the reason why a recurrence condition like (2) of Subsection 3.1 can be used to bound the loss of expansion when an orbit comes near the critical point and to obtain the exponential growth expressed in (1) of Subsection 3.1. Secondly, during the bound, period information of the early iterates of the critical point is passed through continuity to the points returning to the critical region. In order to replicate this in the Hénon family, for every return time  $n$  of the orbit of  $z \in W$  ( $z$  may belong to  $\mathcal{C}$ ) we must associate a suitable binding critical point for  $f^n(z)$  so that we can have some meaning of

the distance of  $f^n(z)$  to the critical set. The suitability depends on the validity of two requirements: tangential position and correct splitting.

3.5.1. *Tangential position and distance to the critical set.* Let  $z \in W$  and  $n$  be one of its return time to the critical region. Let  $\zeta \in \mathcal{C}$ . Essentially we say that  $f^n(z)$  is in tangential position with respect to  $\zeta$  if its horizontal distance to  $\zeta$  is much larger than the vertical distance. In fact we will use the notion of generalized tangential positions introduced in [BY93, Section 1.6.2] instead of the original one from [BC91] (see [BY93, Section 1.4.1]). For  $z \in W$  we say that  $(x', y')$  is the natural coordinate system at  $z$  if  $(0, 0)$  is at  $z$ , the  $x'$  axis is aligned with  $\tau(z)$  and the  $y'$  axis with  $\tau(z)^\perp$ .

**Definition 3.2.** Let  $c > 0$  be a small number much less than  $2a$ , say  $c = 10^{-2}$ , and let  $\zeta \in \mathcal{C}$ . A point  $z$  is said to be in *tangential position* with respect to  $\zeta$ , if  $z = (x', y')$  with  $|y'| \leq cx'^2$ , in the natural coordinate system at  $\zeta$ .

In [BC91, Section 7.2] it is arranged that for every  $\zeta \in \mathcal{C}$  and any  $n$ -th return to the critical region, there is a critical point  $\hat{\zeta}$  of earlier generation with respect to which  $f^n(\zeta)$  is in tangential position. This is done through an argument known as the capture procedure (see also [BY93, Section 2.2.2]) which essentially consists in showing that when a critical orbit  $\zeta \in \mathcal{C}$  experiences a free return at time  $n$ , then  $f^n(\zeta)$  is surrounded by a fairly regular collection of  $C^2(b)$  segments  $\{\gamma_j\}$  of  $W$  which are relatively long and of earlier generations. In fact, we have  $\text{gen}(\gamma_j) \approx 3^j$ ,  $\text{length}(\gamma_j) \approx \rho^{3^j}$  and  $\text{dist}(f^n(\zeta), \gamma_j) \approx b^{3^j}$ , where  $3^j < \theta n$  and  $\theta \approx \frac{1}{|\log b|}$ . Some (maybe all) of these captured segments will have critical points and most locations of  $f^n(\zeta)$  will be in tangential position with respect to one of these critical points. Bad locations of  $f^n(\zeta)$  correspond to deleted parameters. This is another subtlety of Benedicks-Carleson proof: every time a critical point is created it causes a certain amount of parameters to be discarded so we cannot afford to have too many critical points; however, we must have enough critical points so that a convenient one, in tangential position, may be found every time a return occurs.

In [BY93] it is shown that this kind of control when a critical orbit returns can be extended to all points in  $W$ . Thus, for any return of the orbit of  $z \in W$  to the critical region there is an available binding critical point with respect to which the tangential position requirement holds. In fact [BY93, Lemma 7] guarantees that one can systematically assign to each maximal free segment  $\gamma \subset W$  intersecting the critical region a critical point  $\tilde{z}(\gamma)$  with respect to which each  $z \in \gamma$  are in tangential position. When the orbit of  $z \in W$  returns to the critical region, say at time  $n$ , we denote by  $z(f^n(z)) \in \mathcal{C}$  a critical point with respect to which  $f^n(z)$  is in tangential position.

These facts lead us to the notion of distance to the critical set. We do not intend to give a formal definition but rather introduce a concept that gives an indication of closeness to the critical set. In [BC91] and [BY93] two different perspectives of distance to the critical set have been introduced. In [BY00, Section 2] this notion is cleaned up and these two different perspectives are seen to translate essentially the same geometrical facts. Let  $z \in W$ . If  $z = (x, y) \notin (-\delta, \delta) \times \mathbb{R}$  we consider that  $\text{dist}(z, \mathcal{C}) = |x|$ ; if  $z \in (-\delta, \delta) \times \mathbb{R}$  then we pick any critical point  $\zeta \in \mathcal{C}$  with respect to which  $z$  is in tangential position

and let  $\text{dist}(z, \mathcal{C}) = |z - \zeta|$ . In order to this notion make sense one has to verify that if  $\hat{\zeta} \in \mathcal{C}$  is a different critical point with respect to which  $z$  is also in tangential position then  $|z - \zeta| \approx |z - \hat{\zeta}|$ . This is exactly the content of [BY00, Lemma 1'], where it is proved that  $|z - \zeta|/|z - \hat{\zeta}| = 1 + \mathcal{O}(\max(b, d^2))$ , for  $d = \min(|z - \zeta|, |z - \hat{\zeta}|)$ . As observed in [BY00] for a better understanding of the distance of a given point  $z \in W \cap (-\delta, \delta) \times \mathbb{R}$  to the critical set, one should look at the angle between  $\tau(z)$  and  $e_m(z)$ , the most contracted vector at  $z$  of a convenient order  $m$ . The reason for this is that, at the critical points, this angle is extremely close to 0; actually it tends to 0 if we let  $m$  go to infinity.

**3.5.2. Bound period and fold period.** Let  $z \in W \cap (-\delta, \delta) \times \mathbb{R}$  be in tangential position with respect to  $\zeta \in \mathcal{C}$ . Then  $z$  initiates a binding to  $\zeta$  of length  $p$ , where  $p = p(z, \zeta)$  is the largest  $k$  such that

$$|f^j(z) - f^j(\zeta)| < e^{-\beta j}, \quad \forall j < k$$

where  $\beta = 14\alpha$ . We say that in the next  $p$  iterates,  $z$  is bounded to  $\zeta$ . It is convenient to modify slightly the above definition of  $p$  so that the bound periods become nested. This means that if the orbit of  $z$  returns to the critical region before  $p$  then the bound period initiated at that time must cease before the end of the bound relation to  $\zeta$ . This is done in [BC91, Section 6.2]. It is further required that if the bound relation between  $z$  and  $\zeta$  is still in effect at time  $n$ , which is a return time for both, then  $z(f^n(\zeta)) = z(f^n(z))$ .

An additional complication arises in the Hénon maps: the folding. To illustrate it, let  $\gamma \subset W$  be a  $C^2(b)$  segment containing a critical point  $\zeta$ . The practically horizontal vector  $\tau(\zeta)$  will be sent by  $Df$  into an approximately vertical direction, which is the typical contracting direction of the system, and will be contracted forever. After few iterations  $\gamma$  develops very sharp bends at the iterates of  $\zeta$ , which induce an unstable setting near the bends. In fact, if we pick a point  $z \in \gamma$  very close to  $\zeta$ , its iterates diverge very fast from the bends which means that after some time, say  $n$ , depending on how close  $z$  and  $\zeta$  are, the vector  $\tau(f^n(z))$  will be practically aligned with the horizontal direction again, which, on the contrary, is the typical expanding direction of the system. The interval of time that the tangent direction takes to be horizontal again is called the fold period.

The actual definition of fold period is given in [BC91, Sections 6.2 and 6.3]; here, we stick to the previous heuristic motivation and to the following properties. If  $z \in W$  has a return at time  $n$ , the fold period of  $f^n(z)$  with respect to  $z(f^n(z)) \in \mathcal{C}$  is a positive integer  $l = l(f^n(z), z(f^n(z)))$  such that

- (1)  $2m \leq l \leq 3m$ , where  $(5b)^m \leq |f^n(z) - z(f^n(z))| \leq (5b)^{m-1}$ ;
- (2)  $l/p \leq \text{const}/|\log b|$ , that is the fold period associated to a return is very short when compared to the bound period initiated at that time.

**3.5.3. Correct splitting and controlled orbits.** In order to duplicate the 1-dimensional behavior not only one assigns a binding critical point every time a return to the critical region occurs but also one would like to guarantee that the loss of hiperbolicity due to the return is in some sense proportional to the distance to the critical set. This is achieved through the notion of correct splitting.

**Definition 3.3.** Let  $z \in W$ ,  $v \in T_z\mathbb{R}^2$ ,  $n \in \mathbb{N}$  be a return time for  $z$  and consider  $z(f^n(z)) \in \mathcal{C}$  with respect to which  $f^n(z)$  is in tangential position. We say that the vector  $Df^n(z)v$  splits correctly with respect to  $z(f^n(z)) \in \mathcal{C}$  if and only if we have that

$$3|f^n(z) - z(f^n(z))| \leq \angle(Df^n(z)v, e_l(f_n(z))) \leq 5|f^n(z) - z(f^n(z))|,$$

where  $l$  is the fold period associated to the return.

Now we are in condition of defining controlled orbits.

**Definition 3.4.** Let  $z \in W$  and  $v \in T_z\mathbb{R}^2$  and  $N \in \mathbb{N}$ . We say that the pair  $(z, v)$  is controlled on the time interval  $[0, N)$  if for every return  $n \in [0, N)$  of the orbit of  $z$  to the critical region, there is  $z(f^n(z)) \in \mathcal{C}$  with respect to which  $f^n(z)$  is in tangential position and  $Df^n(z)v$  splits correctly with respect to  $z(f^n(z)) \in \mathcal{C}$ . We say that the pair  $(z, v)$  is controlled during the time interval  $[0, \infty)$  if it is controlled on  $[0, N)$  for every  $N \in \mathbb{N}$ .

One of the most important properties of  $f$  proved in [BC91] is that for every  $\zeta \in \mathcal{C}$ , the pair  $(\zeta, \begin{pmatrix} 0 \\ 1 \end{pmatrix})$  is controlled during the time interval  $[0, \infty)$ . This fact supports the validity of the 1-dimensional estimates in the surface case.

We say that the pair  $(z, v)$  is controlled on  $[j, 0)$  with  $-\infty < j < 0$ , if  $(f^j(z), Df^j(z)v)$  is controlled on  $[0, -j)$  and that  $(z, v)$  is controlled on  $(-\infty, 0)$  if it is controlled on  $[j, 0)$  for all  $j < 0$ . In [BY93, Proposition 1] it is proved that if the orbit of  $z \in W$  never hits the critical set  $\mathcal{C}$  then the pair  $(z, \tau(z))$  is controlled in the time interval  $(-\infty, \infty)$ .

**3.6. Dynamics in  $W$ .** As referred, [BY93, Proposition 1] shows that every orbit of  $z \in W$  can be controlled using those of  $\mathcal{C}$ , just as it was done for critical orbits in [BC91]. This means that each orbit in  $W$  can be organized into free periods and bound periods. To illustrate, consider  $z$  belonging to a small segment of  $W$  around the fixed point  $z^*$ . By definition  $z$  is considered to be free at this particular time. The first forward iterates of  $z$  are also in a free state, until the first return to the critical region occurs, say at time  $n$ . Then since the pair  $(z, \tau(z))$  is controlled there is  $z(f^n(z))$  with respect to which  $f^n(z)$  is in tangential position and  $Df^n(z)\tau$  splits correctly. During the next  $p$  iterates we say that  $z$  is bound to the critical point  $z(f^n(z))$ . If  $f^n(z) \in \mathcal{C}$  then the bound period is infinite; otherwise, after the time  $n + p$  the iterates of  $z$  are said to be in free state once again and history repeats itself.

This division of the orbits into free periods, bound periods and the special design of the control of orbits through the tangential position and correct splitting requirements allowed [BY93] to recover the one dimensional estimates. In fact, the loss of expansion at the returns is somehow proportional to the distance to the binding critical point and it is completely overcome at the end of the bound period.

The following estimates, unless otherwise mentioned, are proved in [BY93, Corollary 1].

(1) Free period estimates.

- (a) Every free segment  $\gamma$  has slope less than  $2b/\delta$ , and  $\gamma \cap (-\delta, \delta) \times \mathbb{R}$  is a  $C^2(b)$  curve (Lemmas 1 and 2 of [BY93]);
- (b) There is  $c_0 > 0$  and  $M_0 \in \mathbb{N}$  such that if  $z$  is free and  $z, \dots, f^{k-1}(z) \notin (-\delta, \delta) \times \mathbb{R}$  with  $k \geq M_0$  then  $|Df^k(z)\tau| \geq e^{c_0 k}$ ;

- (c) There is  $c_0 > 0$  such that if  $z$  is free,  $z, \dots, f^{k-1}(z) \notin (-\delta, \delta) \times \mathbb{R}$  and  $f^k(z) \in (-\delta, \delta) \times \mathbb{R}$  then  $|Df^k(z)\tau| \geq e^{c_0 k}$ .
- (2) Bound period estimates.  
 There is  $c \approx \log 2$  such that if  $z \in (-\delta, \delta) \times \mathbb{R}$  is free and initiates a binding to  $\zeta \in \mathcal{C}$  with bound period  $p$ , then
- (a) If  $e^{-m-1} \leq |z - \zeta| \leq e^{-m}$ , then  $\frac{1}{2}m \leq p \leq 5m$ ;
  - (b)  $|Df^j(z)\tau| \geq |z - \zeta|e^{cj}$  for  $0 < j < p$ .
  - (c)  $|Df^p(z)\tau| \geq e^{c\frac{p}{3}}$ .
- (3) Orbits ending in free states.  
 There exists  $c_1 > \frac{1}{3} \log 2$  such that if  $z \in W \cap (-\delta, \delta) \times \mathbb{R}$  is in a free state, then  $|Df^{-j}(z)\tau| \leq e^{-c_1 j}$ , for all  $j \geq 0$  ([BY93, Lemma 3]).

3.6.1. *Derivative estimate.* The next derivative estimate can be found in [BY00, Section 1.4]. It is the 2-dimensional analogue to the 1-dimensional derivative estimate expressed in Subsection 3.1.4. Consider  $n \in \mathbb{N}$  and a point  $z$  belonging to a free segment of  $W$  and satisfying, for every  $j < n$

$$\text{dist}(f^j(z), \mathcal{C}) \geq \delta e^{-\alpha j}. \quad (SA)$$

Then there is a constant  $c_2 > 0$  such that

$$|Df^n(z)\tau| \geq \delta e^{c_2 n}. \quad (EE)$$

Essentially this estimate is saying that if we have slow approximation to the critical set (or, in other words, a  $(BA)$  type property), then we have exponential expansion along the tangent direction to  $W$ .

3.6.2. *Bookkeeping and bounded distortion.* For  $x_0 \in \mathbb{R}$ , we let  $\mathcal{P}_{[x_0]}$  denote the partition  $\mathcal{P}$  defined in (3.1) after being translated from 0 to  $x_0$ . Similarly, if  $\gamma$  is a roughly horizontal curve in  $\mathbb{R}^2$  and  $z_0 = (x_0, y_0) \in \gamma$ , we let  $\mathcal{P}_{[z_0]}$  denote the partition of  $\gamma$  that projects vertically onto  $\mathcal{P}_{[x_0]}$  on the  $x$ -axis. Once  $\gamma$  and  $z_0$  are specified, we will use  $I_{m,j}$  to denote the corresponding subsegment of  $\gamma$ .

Let  $\gamma \subset (-\delta, \delta) \times \mathbb{R}$  be a segment of  $W$ . We assume that the entire segment has the same itinerary up to time  $n$  in the sense that:

- all  $z \in \gamma$  are bound or free simultaneously at any moment;
- if  $0 = t_0 < t_1 < \dots < t_q$  are the consecutive free return times before  $n$ , then for all  $j \leq q$  the entire segment  $f^{t_j}\gamma$  has a common binding point  $\zeta_j \in \mathcal{C}$  and  $f^{t_j}\gamma \subset 5I_{m,k}^j$  for some  $I_{m,k}^j \in \mathcal{P}_{[\zeta_j]}$ .

Then there exists  $C_1 > 0$  independent of  $\gamma$  and  $n$  such that for all  $z_1, z_2 \in \gamma$

$$\frac{|Df^n(z_1)\tau|}{|Df^n(z_2)\tau|} \leq C_1.$$

This result can be found in [BY93, Proposition 2].

**3.7. Dynamical and geometric description of the critical set.** The construction of the critical set seems to be done according to a quite discretionary set of rules. However, as observed in [BY93] there are certain intrinsic characterizations of  $\mathcal{C}$ . Corollary 1 of [BY93] gives the following dynamical description of  $\mathcal{C}$ . Let  $z \in W$ . Then

$$z \text{ lies on a critical orbit} \quad \Leftrightarrow \quad \limsup_{n \rightarrow \infty} |Df^n(z)\tau| < \infty \quad \Leftrightarrow \quad \limsup_{n \rightarrow \infty} |Df^n(z)\tau| = 0.$$

In fact,  $z \in \mathcal{C}$  if and only if  $|Df^j(z)\tau| \leq e^{-c_1|j|}$ , for all  $j \in \mathbb{Z}$ , i.e. the critical points correspond to the tangencies of Pesin stable manifolds with  $W$  which endow an homoclinic type behavior.

The critical set  $\mathcal{C}$  has also a nice geometric characterization. Given  $\zeta \in W$ ,  $\kappa(\zeta)$  denotes the curvature of  $W$  at  $\zeta$ . From the curvature computations in [BC91, Section 7.6] (see also [BY93, Section 2.1.3]) one gets that

$$z \in \mathcal{C} \quad \Leftrightarrow \quad \kappa(z) \ll 1 \quad \text{and} \quad \kappa(f^n(z)) > b^{-n}, \quad \forall n \in \mathbb{N}.$$

This means that one can look at the critical points as the points that are sent into the folds of  $W$ .

**3.8. SRB measures.** We begin by giving a formal definition of *Sinai-Ruelle-Bowen measures* (SRB measures). Let  $f : M \rightarrow M$  be an arbitrary  $C^2$  diffeomorphism of a finite dimensional manifold and let  $\mu$  be an  $f$  invariant probability measure on  $M$  with compact support. We will assume that  $\mu$ -a.e. point, there is a strictly positive Lyapunov exponent. Under these conditions, the unstable manifold theorem of Pesin [Pe78] or Ruelle [Ru79] asserts that passing through  $\mu$ -a.e.  $z$  there is an unstable manifold which we denote by  $\gamma^u(z)$ .

A measurable partition  $\mathcal{L}$  of  $M$  is said to be *subordinate* to  $\gamma^u$  (with respect to the measure  $\mu$ ) if at  $\mu$ -a.e.  $z$ ,  $\mathcal{L}(z)$  is contained in  $\gamma^u(z)$  and contains an open neighborhood of  $z$  in  $\gamma^u(z)$ , where  $\mathcal{L}(z)$  denotes the atom of  $\mathcal{L}$  containing  $z$ . By Rokhlin's desintegration theorem there exists a family  $\{\mu_z^{\mathcal{L}}\}$  of conditional measures of  $\mu$  with respect to the partition  $\mathcal{L}$  (see for example [BDV05, Appendixes C.4 and C.6]).

**Definition 3.5.** Let  $f : M \rightarrow M$  and  $\mu$  be as above. We say that  $\mu$  is an SRB probability measure if for every measurable partition  $\mathcal{L}$  subordinate to  $\gamma^u$ , we have that  $\{\mu_z^{\mathcal{L}}\}$  is absolutely continuous with respect to Lebesgue measure in  $\gamma^u(z)$  for  $\mu$ -a.e.  $z$ .

In [BY93] it is proved that  $f_{a,b}$  admits an SRB measure  $\nu_{a,b}$ , for every  $(a,b) \in \mathcal{BC}$ . Moreover,  $\nu_{a,b}$  is unique (hence ergodic), it is a physical measure, its support is  $\overline{W}_{a,b}$  and  $(f_{a,b}, \nu_{a,b})$  is isomorphic to a Bernoulli shift.

#### 4. A HORSESHOE WITH POSITIVE MEASURE

In order to obtain decay of correlations for Hénon maps of the Benedicks-Carleson type, Benedicks and Young build, in [BY00], a set  $\Lambda$  of positive SRB-measure with good hyperbolic properties.  $\Lambda$  has hyperbolic product structure and it may be looked at as a horseshoe with infinitely many branches and unbounded return times; it is obtained by intersecting two families of  $C^1$  stable and unstable curves. Dynamically,  $\Lambda$  can be decomposed into a

countable union of  $s$ -sublattices, denoted  $\Xi_i$ , crossing  $\Lambda$  completely in the stable direction, with a Markov type property: for each  $\Xi_i$  there is  $R_i \in \mathbb{N}$  such that  $f^{R_i}(\Xi_i)$  is an  $u$ -sublattice of  $\Lambda$ , crossing  $\Lambda$  completely in the unstable direction. The intersection of  $\Lambda$  with every unstable leaf is a positive 1-dimensional Lebesgue measure set. Before continuing with an overview of the construction of such horseshoes, we mention that Young [Yo98] has extended the argument in [BY00] to a wider setting and observed that similar horseshoes can be found in other situations. We will refer to [Yo98] for certain facts not specific to Hénon maps.

Let  $\Gamma^u$  and  $\Gamma^s$  be two families of  $C^1$  curves in  $\mathbb{R}^2$  such that

- the curves in  $\Gamma^u$ , respectively  $\Gamma^s$ , are pairwise disjoint;
- every  $\gamma^u \in \Gamma^u$  meets every  $\gamma^s \in \Gamma^s$  in exactly one point;
- there is a minimum angle between  $\gamma^u$  and  $\gamma^s$  at the point of intersection.

Then we define the lattice associated to  $\Gamma^u$  and  $\Gamma^s$  by

$$\Lambda := \{\gamma^u \cap \gamma^s : \gamma^u \in \Gamma^u, \gamma^s \in \Gamma^s\}.$$

For  $z \in \Lambda$  let  $\gamma^u(z)$  and  $\gamma^s(z)$  denote the curves in  $\Gamma^u$  and  $\Gamma^s$  containing  $z$ , respectively.

We say that  $\Xi$  is an  $s$ -sublattice (resp.  $u$ -sublattice) of  $\Lambda$  if  $\Lambda$  and  $\Xi$  have a common defining family  $\Gamma^u$  (resp.  $\Gamma^s$ ) and the defining family  $\Gamma^s$  (resp.  $\Gamma^u$ ) of  $\Lambda$  contains that of  $\Xi$ . A subset  $Q \subset \mathbb{R}^2$  is said to be the *rectangle spanned* by  $\Lambda$  if  $\Lambda \subset Q$  and  $\partial Q$  is made up of two curves from  $\Gamma^s$  and two from  $\Gamma^u$ .

Next, we state Proposition A from [BY00] which asserts the existence of two lattices  $\Lambda^+$  and  $\Lambda^-$  with essentially the same properties; for notation simplicity statements about  $\Lambda$  apply to both  $\Lambda^+$  and  $\Lambda^-$ .

**Proposition 4.1.** *There are two lattices  $\Lambda^+$  and  $\Lambda^-$  in  $\mathbb{R}^2$  with the following properties.*

- (1) *(Topological Structure)*  $\Lambda$  is the disjoint union of  $s$ -sublattices  $\Xi_i$ ,  $i = 1, 2, \dots$ , where for each  $i$ , exists  $R_i \in \mathbb{N}$  such that  $f^{R_i}(\Xi_i)$  is a  $u$ -sublattice of  $\Lambda^+$  or  $\Lambda^-$ .
- (2) *(Hyperbolic estimates)*
  - (a) Every  $\gamma^u \in \Gamma^u$  is a  $C^2(b)$  curve; and exists  $\lambda_1 > 0$  such that for all  $z \in \gamma^u \cap Q_i$ ,

$$|Df^{R_i}(z)\tau| \geq \lambda_1^{R_i},$$

where  $\tau$  is the unit tangent vector to  $\gamma^u$  at  $z$  and  $Q_i$  is the rectangle spanned by  $\Xi_i$ .

- (b) For all  $z \in \Lambda$ ,  $\zeta \in \gamma^s(z)$  and  $j \geq 1$  we have

$$|f^j(z) - f^j(\zeta)| < Cb^j,$$

- (3) *(Measure estimate)*  $\text{Leb}(\Lambda \cap \gamma^u) > 0$ ,  $\forall \gamma^u \in \Gamma^u$ .
- (4) *(Return time estimates)* Let  $R : \Lambda \rightarrow \mathbb{N}$  be defined by  $R(z) = R_i$  for  $z \in \Xi_i$ . Then there are  $C_0 > 0$  and  $\theta_0 < 1$  such that on every  $\gamma^u$

$$\text{Leb}\{z \in \gamma^u : R(z) \geq n\} \leq C_0\theta_0^n, \quad \forall n \geq 1.$$

The proof of Proposition 4.1 can be found in Sections 3 and 4 of [BY00]. Since we will need to prove the closeness of these horseshoes for nearby Benedicks-Carleson parameters

and this involves slight modifications in the construction of the horseshoes themselves, we will include, for the sake of completeness, the basic ideas of the major steps leading to  $\Lambda$ .

Consider the leaf of first generation  $W_1$  and the unique critical point  $z_0 = (x_0, y_0) \in \mathcal{C}$  on it. Take the two outermost intervals of the partition  $\mathcal{P}_{[x_0]}$  as in Subsection 3.6.2 and denote them by  $\Omega_0^+$  and  $\Omega_0^-$ ; they support the construction of the lattices  $\Lambda^+$  and  $\Lambda^-$ , respectively. Again we use  $\Omega_0$  to simplify notation and statements regarding to it apply to both  $\Omega_0^+$  and  $\Omega_0^-$ .

Let  $h : \Omega_0 \rightarrow \mathbb{R}$  be a function whose graph is the leaf of first generation  $W_1$ , when restricted to the set  $\Omega_0 \times \mathbb{R}$  and  $H : \Omega_0 \rightarrow W_1$  be given by  $H(x) = (x, h(x))$ .

**4.1. Leading Cantor sets.** The first step is to build the Cantor set that constitutes the intersection of  $\Lambda$  with the leaf of first generation  $W_1$ . We build a sequence  $\Omega_0 \supset \Omega_1 \supset \Omega_2 \dots$  such that for every  $z \in H(\Omega_n)$ ,  $\text{dist}(f^j(z), \mathcal{C}) \geq \delta e^{-\alpha j}$ , for all  $j \in \{1, 2, \dots, n\}$ . This is done by excluding from  $\Omega_{n-1}$  the points that at step  $n$  fail to satisfy the condition  $\text{dist}(f^n(H(x)), \mathcal{C}) \geq \delta e^{-\alpha n}$ . Then we define the Cantor set  $\Omega_\infty = \bigcap_{n \in \mathbb{N}} \Omega_n$ . By the derivative estimate in Subsection 3.6.1, on  $H(\Omega_\infty)$ , the condition (SA) holds and thus  $|Df^n(z)\tau(z)| > e^{c_1 n}$ , for all  $n \in \mathbb{N}$ .

*Remark 4.2.* We observe that there is a difference in the notation used in [BY00]: in here, the sets  $\Omega_n$  (with  $n = 0, 1, \dots, \infty$ ) are the vertical projections in the  $x$ -axis of the corresponding sets in [BY00].

*Remark 4.3.* We note that the procedure leading to  $\Omega_\infty$  is not unique.  $\Omega_\infty$  is obtained by successive exclusions of points from the set  $\Omega_0$ . These exclusions are made according to the distance to a suitable binding critical point every time we have a free return to  $[-\delta, \delta] \times \mathbb{R}$ . Certainly, the choice for the binding critical point is not unique which leads to different exclusions. However, by the results referred in Subsection 3.5.1 all suitable binding points are essentially the same and these possible differences in the exclusions are insignificant in terms of the properties we want  $\Omega_\infty$  to have: slow approximation to the critical set and expansion along the tangent direction to  $W$ .

**4.2. Construction of long stable leaves.** The next step towards building  $\Lambda$  involves the construction of long stable curves,  $\gamma^s(z)$ , at every  $z \in H(\Omega_\infty)$ . This is done in Lemma 2 of [BY00]; let us review the inductive procedure used there.

The contracting vector field of order 1,  $e_1$ , is defined everywhere so we may consider the rectangle  $Q_0(\omega_0) = \cup_{z \in \omega_0} \gamma_1(z)$ , where  $\gamma_1(z)$  denotes the  $e_1$ -integral curve segment  $10b$  long to each side of  $z \in \omega_0$  and  $\omega_0 = H(\Omega_0)$ . Let also  $Q_0^1(\omega_0)$  denote the  $Cb$ -neighborhood of  $Q_0(\omega_0)$  in  $\mathbb{R}^2$ . We observe that by (1) of Section 3.3 the  $\gamma_1$  curves in  $Q_0(\omega_0)$  have slopes  $\approx \pm 2a\delta$  depending on whether  $\Omega_0$  refers to  $\Omega_0^+$  or  $\Omega_0^-$ .

Suppose that for every connected component  $\omega \in H(\Omega_{n-1})$  we have a strip foliated by integral curves of  $e_n$ ,  $Q_{n-1}(\omega) = \cup_{z \in \omega} \gamma_n(z)$ , where  $\gamma_n(z)$  denotes the  $e_n$ -integral curve segment  $10b$  long to each side of  $z \in \omega$ . From [BY00, Section 3.3] one deduces that the vector field  $e_{n+1}$  is defined on a  $3(Cb)^n$  neighborhood of each curve  $\gamma_n(z)$ , if  $z \in H(\Omega_n)$ . Consider the  $(Cb)^n$ -neighborhood of  $Q_{n-1}(\omega)$  in  $\mathbb{R}^2$ , denoted by  $Q_{n-1}^1(\omega)$ . If  $\tilde{\omega} \subset \omega$  is a



connected component of  $H(\Omega_n)$  then  $Q_n(\tilde{\omega}) = \cup_{z \in \tilde{\omega}} \gamma_{n+1}(z)$  is defined and

$$Q_n^1(\tilde{\omega}) \subset Q_{n-1}^1(\omega), \quad (4.1)$$

where  $Q_n^1(\tilde{\omega})$  is a  $(Cb)^{n+1}$ -neighborhood of  $Q_n(\tilde{\omega})$  in  $\mathbb{R}^2$ .

To fix notation, for some  $\omega \subset H(\Omega_0)$  and  $n \in \mathbb{N}$ , when defined,  $Q_n(\omega) = \cup_{z \in \omega} \gamma_{n+1}(z)$  denotes a rectangle foliated by integral curves of  $e_{n+1}$  passing through  $z \in \omega$  and  $10b$  long to each side of  $z$ . Besides,  $Q_n^1(\omega)$  is a  $(Cb)^{n+1}$ -neighborhood of  $Q_n(\omega)$  in  $\mathbb{R}^2$ .

To finish the construction of  $\gamma^s(z)$ , for each  $z \in H(\Omega_\infty)$ , take the sequence of connected components  $\omega_i \subset H(\Omega_i)$  containing  $z$ . We have  $\{z\} = \cap_i \omega_i$ . Let  $z_n$  denote the right end point of  $\omega_{n-1}$ . Then  $\gamma_n(z_n)$  converges in the  $C^1$ -norm to a  $C^1$ -curve  $\gamma^s(z)$  with the properties stated in Proposition 4.1. The curve  $\gamma_n(z_n)$  acts as an approximate long stable leaf of order  $n$ . Note that the choice of the right end point is quite arbitrary; in fact any curve  $\gamma_n(\zeta)$  with  $\zeta \in \omega_{n-1}$  suits as an approximate stable leaf of order  $n$ .

**4.3. The families  $\Gamma^u$  and  $\Gamma^s$ .** The final step in the construction of  $\Lambda$  is to specify the families  $\Gamma^u$  and  $\Gamma^s$ . Set

$$\Gamma^s := \{\gamma^s(z) : z \in \Omega_\infty\},$$

where  $\gamma^s(z)$  is obtained as described in Subsection 4.2. Consider  $\tilde{\Gamma}^u := \{\gamma \subset W : \gamma \text{ is a } C^2(b) \text{ segment connecting } \partial^s Q_0\}$ , where  $Q_0$  is the rectangle spanned by the family of curves  $\Gamma^s$ , i.e.,  $Q_0 \supset \cup_{z \in H(\Omega_\infty)} \gamma^s(z)$  and  $\partial Q_0$  is made up from two curves of  $\Gamma^s$ . Set

$$\Gamma^u := \{\gamma : \gamma \text{ is the pointwise limit of a sequence in } \tilde{\Gamma}^u\}.$$

**4.4. The  $s$ -sublattices and the return times.** Recall that we are interested in two lattices  $\Lambda^+$  and  $\Lambda^-$ . Therefore, when we refer to return times we mean return times from the set  $\Lambda^+ \cup \Lambda^-$  to itself; in particular, a point in  $\Lambda^+$  may return to  $\Lambda^+$  or  $\Lambda^-$ . However, in order to simplify we just write  $\Lambda$ .

We anticipate that the return time function  $R : \Lambda \rightarrow \mathbb{N}$  is constant in each  $\gamma^s \in \Gamma^s$ , so  $R$  needs only to be defined in  $\Lambda \cap H(\Omega_0) = H(\Omega_\infty)$ . Moreover, since  $H : \Omega_0 \rightarrow W_1$  is a bijection we may also look at  $R$  as being defined on  $\Omega_\infty$ . We will build partitions on subsets of  $\Omega_0$  and use 1-dimensional language. For example,  $f^n(z) = \zeta$  for  $z, \zeta \in H(\Omega_\infty)$  means that  $f^n(z) \in \gamma^s(\zeta)$ ; similarly, for subsegments  $\omega, \omega^* \subset H(\Omega_0)$ ,  $f^n(\omega) = \omega^*$  means that  $f^n(\omega) \cap \Lambda$ , when slid along  $\gamma^s$  curves back to  $H(\Omega_0)$ , gives exactly  $\omega^* \cap \Lambda$ . For an interval  $I \subset \Omega_{n-1}$  such that  $f^n(H(I))$  intersects the critical region,  $\mathcal{P}|f^n(H(I))$  refers to  $\mathcal{P}_{[\tilde{z}]}$  where  $\tilde{z} \in \mathcal{C}$  is a suitable binding critical point for all  $f^n(H(I))$  whose existence is a consequence of Lemma 7 from [BY93], mentioned in Subsection 3.5.1.

We will construct sets  $\tilde{\Omega}_n \subset \Omega_n$  and partitions  $\tilde{\mathcal{P}}_n$  of  $\tilde{\Omega}_n$  so that  $\tilde{\Omega}_0 \supset \tilde{\Omega}_1 \supset \tilde{\Omega}_2 \dots$  and  $z \in H(\tilde{\Omega}_{n-1} \setminus \tilde{\Omega}_n)$  if and only if  $R(z) = n$ . Let  $\hat{\mathcal{P}}$  be the partition of  $H(\Omega_0 \setminus \Omega_\infty)$  into connected components. In what follows  $\mathcal{A} \vee \mathcal{B}$  is the join of the partitions  $\mathcal{A}$  and  $\mathcal{B}$ , that is  $\mathcal{A} \vee \mathcal{B} = \{A \cap B : A \in \mathcal{A}, B \in \mathcal{B}\}$ .

**Definition 4.4.** An interval  $I \in \Omega_n$  is said to make a *regular return* to  $\Omega_0$  at time  $n$  if

- (i) all of  $f^n(H(I))$  is free;

(ii)  $f^n(H(I)) \supset 3H(\Omega_0)$ .

*Remark 4.5.* The constant 3 in the definition of regular return is quite arbitrary. In fact its purpose is to guarantee that  $f^n(H(I))$  traverses  $Q_0$  by wide margins. When  $n$  is a regular return of a certain segment  $I$  for a fixed parameter it may happen that  $n$  does not classify as a regular return of a perturbed parameter even though the image of  $I$  after  $n$  iterates by the perturbed dynamics crosses  $Q_0$  by wide margins. We overcome this detail simply by considering that if (ii) holds with 2 instead of 3 for any perturbed parameter then we consider  $n$  as a regular return for the perturbed dynamics. Observe that no harm results from making this assumption since it is still guaranteed that  $Q_0$  is traversed by wide margins.

4.4.1. *Rules for defining  $\tilde{\Omega}_n$ ,  $\tilde{\mathcal{P}}_n$  and  $R$ .*

(0)  $\tilde{\Omega}_0 = \Omega_0$ ,  $\tilde{\mathcal{P}}_0 = \{\tilde{\Omega}_0\}$ .

Consider  $I \in \tilde{\mathcal{P}}_{n-1}$ .

(1) If  $I$  does not make a regular return to  $\Omega_0$  at time  $n$ , put  $I \cap \Omega_n$  into  $\tilde{\Omega}_n$  and set  $\tilde{\mathcal{P}}_n|_{(I \cap \Omega_n)} = H^{-1}((f^{-n}\mathcal{P})|(H(I \cap \Omega_n)))$ .

(2) If  $I$  makes a regular return at time  $n$ , we put  $\tilde{I} = H^{-1}(H(I) \setminus f^{-n}(H(\Omega_\infty))) \cap \Omega_n$  in  $\tilde{\Omega}_n$ , and let  $\tilde{\mathcal{P}}_n|\tilde{I} = H^{-1}((f^{-n}\mathcal{P} \vee f^{-n}\hat{\mathcal{P}})|H(\tilde{I}))$ . For  $z \in H(I)$  such that  $f^n(z) \in H(\Omega_\infty)$ , we define  $R(z) = n$ .

(3) For  $z \in H(\cap_{n \in \mathbb{N}_0} \tilde{\Omega}_n)$ , set  $R(z) = \infty$ .

4.4.2. *Definition of the  $s$ -sublattices.* Each  $\Xi_i$  in Proposition 4.1 is a sublattice corresponding to a subset of  $\Lambda \cap W_1$  of the form  $f^{-n}(H(\Omega_\infty)) \cap \Lambda \cap H(I)$ , where  $I \in \tilde{\mathcal{P}}_{n-1}$  makes a regular return at time  $n$ . We will use the notation  $\Upsilon_{n,j} = H^{-1}(f^{-n}(H(\Omega_\infty)) \cap \Lambda \cap H(I))$ . Note that  $R(H(\Upsilon_{n,j})) = n$  and  $\Upsilon_{n,j}$  determines univocally the corresponding  $s$ -sublattice. For this reason we allow some imprecision by referring ourselves to  $\Upsilon_{n,j}$  as an  $s$ -sublattice.

In order to prove the assertions (1) and (2) of Proposition 4.1 one needs to verify that  $f^{R_i}(\Xi_i)$  is an  $u$ -sublattice which requires to demonstrate that  $f^{R_i}(\Xi_i)$  matches completely with  $\Lambda$  in the horizontal direction. If  $\Xi_i$  corresponds to some  $\Upsilon_{n,j}$ , then the matching of the Cantor sets will follow from the inclusion

$$f^n(H(I \cap \Omega_\infty)) \supset H(\Omega_\infty). \quad (4.2)$$

It is obvious that  $H(\Omega_\infty) \subset f^n(H(I))$  by definition of regular return. Nevertheless, (4.2) is saying that if  $z \in H(I)$  and  $f^n(z)$  hits  $H(\Omega_\infty)$ , after sliding along a  $\gamma^s$  curve, then  $z \in H(I) \cap H(\Omega_\infty)$ . This is proved in Lemma 3 of [BY00]. In particular, we may write  $\Upsilon_{n,j} = H^{-1}(f^{-n}(H(\Omega_\infty)) \cap H(I))$ .

**4.5. Reduction to an expanding map.** The Hénon maps considered here are perturbations of the map  $f_{2,0}(x, y) = (1 - 2x^2, 0)$  whose action is horizontal. Also, as we have seen, the horizontal direction is typically expanding. This motivates considering the quotient space  $\bar{\Lambda}$  obtained by collapsing the stable curves of  $\Lambda$ ; i.e.  $\bar{\Lambda} = \Lambda / \sim$ , where  $z \sim z'$  if and only if  $z' \in \gamma^s(z)$ . We define the natural projection  $\bar{\pi} : \Lambda \rightarrow \bar{\Lambda}$  given by  $\bar{\pi}(z) = \gamma^s(z)$ . As implied by assertion (1) of Proposition 4.1,  $f^R : \Lambda \rightarrow \Lambda$  takes  $\gamma^s$  leaves to  $\gamma^s$  leaves (see

Lemma 2 of [BY00] for a proof). Thus, we may define the quotient map  $\overline{f^R} : \overline{\Lambda} \rightarrow \overline{\Lambda}$ . Observe that each  $\overline{\Xi}_i$  is sent by  $\overline{f^R}$  homeomorphically onto  $\overline{\Lambda}$ . Besides we may define a *reference measure*  $\overline{m}$  on  $\overline{\Lambda}$ , whose representative on each  $\gamma^u \in \Gamma^u$  is a finite measure equivalent to the restriction of the 1-dimensional Lebesgue measure on  $\gamma^u \cap \Lambda$  and denoted by  $m_{\gamma^u}$ .

One can look at  $\overline{f^R}$  as an expanding Markov map (see Proposition B of [BY00] for precise statements and proofs). Moreover, the corresponding transfer operator, relative to the reference measure  $\overline{m}$ , has a spectral gap (see Section 3 of [Yo98], specially Proposition A). It follows that  $\overline{f^R}$  has a unique ergodic absolutely continuous invariant probability measure  $\overline{\nu} = \overline{\rho} d\overline{m}$ , with  $M^{-1} \leq \overline{\rho} \leq M$  for some  $M > 0$ ; see [Yo98, Lemma 2].

## 5. PROXIMITY OF CRITICAL SETS

In this section we show that up to a fixed generation we have closeness of the critical points for nearby Benedicks-Carleson parameters. This is the content of Proposition 5.3 which summarizes this section. Its proof involves a finite step induction scheme on the generation level. We prepare it by proving first the closeness of critical points of generation 1 in Lemma 5.1. Afterwards, in Lemma 5.2 we obtain the closeness of critical points of higher generations using the information available for lower ones. A similar conclusion was obtained in [WY01, Lemma 6.4] in a different setting.

Recall that since  $f_{a,b}$  is  $C^\infty$ , then the unstable manifold theorem ensures that  $W$  is  $C^r$  for any  $r > 0$ . Moreover,  $W$  varies continuously in the  $C^r$  topology with the parameters in compact parts. As we are only considering parameters in  $\mathcal{BC}$ , for each of these dynamics there is a unique critical point  $\hat{z}$  of generation 1 situated on the roughly horizontal segment of  $W$  containing the fixed point  $z^*$ .

**Lemma 5.1.** *Let  $(a, b) \in \mathcal{BC}$ ,  $\varepsilon > 0$  be given and  $\hat{z}$  be the critical point of generation 1 of  $f_{a,b}$ . There exists a neighborhood  $\mathcal{U}$  of  $(a, b)$  such that, if  $(a', b') \in \mathcal{U} \cap \mathcal{BC}$  and  $\hat{z}'$  denotes the critical point of  $f_{a',b'}$  of generation 1, then  $|\hat{z} - \hat{z}'| < \varepsilon$ . Moreover, if  $\tau(\hat{z})$  and  $\tau(\hat{z}')$  are the unit vectors tangent to  $W$  and  $W'$  at  $\hat{z}$  and  $\hat{z}'$  respectively, then  $|\tau(\hat{z}) - \tau(\hat{z}')| < \varepsilon$ .*

*Proof.* Consider the disk  $\gamma = W_1 \cap [-10b, 10b] \times \mathbb{R}$ . There is a neighborhood  $\mathcal{U}$  of  $(a, b)$  such that for every  $(a', b') \in \mathcal{U}$  there exists a disk  $\gamma' \subset W'$  which is  $\varepsilon^2$ -close to  $\gamma$  in the  $C^r$  topology. It is clear that both  $\gamma$  and  $\gamma'$  are  $C^2(b)$  curves and there are  $\hat{z} \in \gamma$  and  $\hat{z}' \in \gamma'$  critical points of  $f_{a,b}$  and  $f_{a',b'}$  respectively. Our goal is to show that  $|\hat{z} - \hat{z}'| < \varepsilon$ . The strategy is to pick an approximate critical point  $\hat{z}_M$  of  $\hat{z}$  and then prove the existence of an approximate critical point  $\hat{z}'_M$  of  $\hat{z}'$  sufficiently close to  $\hat{z}_M$  in order to conclude that, if we choose  $M$  large enough, we get the desired closeness of  $\hat{z}$  and  $\hat{z}'$  (see Figure 1). Take  $M \in \mathbb{N}$  so that  $b^M < \varepsilon^2 \leq b^{M-1}$ . Let  $\hat{z}_M \in \gamma$  be such that  $e_M(\hat{z}_M) = \tau(\hat{z}_M)$ . Note that  $|\hat{z} - \hat{z}_M| < Cb^M$ . Let  $\hat{z}''_M \in \gamma'$  be such that  $|\hat{z}_M - \hat{z}''_M| < \varepsilon^2$  and  $|\tau(\hat{z}_M) - \tau(\hat{z}''_M)| < \varepsilon^2$ . Now,  $\hat{z}''_M$  may not be the approximate critical point  $\hat{z}'_M$  we are looking for, but we will show that it is very close to  $\hat{z}'_M$ . In fact, we assert that the angle between  $e'_M(\hat{z}''_M)$  and  $\tau(\hat{z}''_M)$  is of order  $\varepsilon^2$ , which allows us to find a nearby  $\hat{z}'_M$  as a solution of  $e'_M(\hat{z}'_M) = \tau(\hat{z}'_M)$ , which ultimately is very close to the critical point  $\hat{z}'$ .

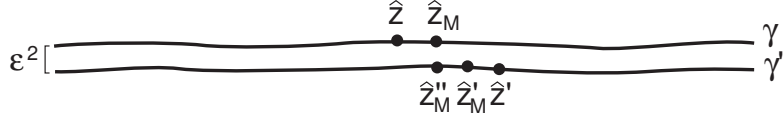

FIGURE 1. Possible configuration of the critical points and their approximates

Before we prove this last assertion we must guarantee that the vector field  $e'_M$  is defined in a neighborhood of  $\hat{z}''_M$  and for that we must have some expansion. Since  $\hat{z}$  is a critical point of  $f_{a,b}$ , then  $|Df_{a,b}^M(\hat{z}) \binom{0}{1}| > e^{cM}$ . If necessary we tighten  $\mathcal{U}$  so that for every  $z$  in a compact set of  $\mathbb{R}^2$ ,  $|Df_{a,b}^M(z) \binom{0}{1} - Df_{a',b'}^M(z) \binom{0}{1}|$  is small enough for having  $|Df_{a',b'}^M(\hat{z}) \binom{0}{1}| > e^{cM/2}$ , which implies that  $e'_M$  is well defined in a ball of radius  $3Cb^{M-1} > 3C\varepsilon^2$  around  $\hat{z}$ . Note that  $b \ll \lambda$  and the Matrix Perturbation Lemma applies.

We take  $\mathcal{U}$  sufficiently small so that  $|e'_M(\hat{z}''_M) - e_M(\hat{z}''_M)| < \varepsilon^2$ . This is possible because  $e'_M(z)$  and  $e_M(z)$  are the maximally contracted vectors of  $Df_{a',b'}^M(z)$  and  $Df_{a,b}^M(z)$ , respectively. Thus it is only a matter of making  $Df_{a',b'}^M(z)$  very close to  $Df_{a,b}^M(z)$ , for every  $z$  in a compact set. Hence

$$\begin{aligned} |e'_M(\hat{z}''_M) - \tau(\hat{z}''_M)| &< |e'_M(\hat{z}''_M) - e_M(\hat{z}''_M)| + |e_M(\hat{z}''_M) - e_M(\hat{z}_M)| + |e_M(\hat{z}_M) - \tau(\hat{z}_M)| \\ &\quad + |\tau(\hat{z}_M) - \tau(\hat{z}''_M)| \\ &< \varepsilon^2 + C|\hat{z}_M - \hat{z}''_M| + 0 + \varepsilon^2 \\ &< C\varepsilon^2 \end{aligned}$$

Writing  $z = (x, y)$  and taking into account that  $\gamma'$  is nearly horizontal we may think of it as the graph of  $\gamma'(x)$ . Let us also ease on the notation so that  $\tau(x)$  and  $e'_M(x)$  denote the slopes of the respective vectors at  $z = \gamma'(x)$ . We know that  $|d\tau/dx| < 10b$ ,  $|de'_M/dx| = 2a + \mathcal{O}(b)$  and  $|d^2e'_M/dx^2| < C$ . As a consequence we obtain  $\hat{z}'_M$  such that  $e'_M(\hat{z}'_M) = \tau(\hat{z}_M)$  and  $|\hat{z}'_M - \hat{z}''_M| < C\varepsilon^2/3$  (see Figure 2). Now since there is a unique critical point  $\hat{z}'$  in  $\gamma'$  we must have  $|\hat{z}' - \hat{z}'_M| < C\varepsilon^2$ , which yields

$$|\hat{z} - \hat{z}'| \leq |\hat{z} - \hat{z}_M| + |\hat{z}_M - \hat{z}''_M| + |\hat{z}''_M - \hat{z}'_M| + |\hat{z}'_M - \hat{z}'| < C\varepsilon^2 < \varepsilon,$$

as long as  $\varepsilon$  is sufficiently small.

Concerning the inequality  $|\tau(\hat{z}) - \tau(\hat{z}')| < \varepsilon$ , simply observe that since  $\gamma$  and  $\gamma'$  are  $C^2(b)$  curves we have

$$\begin{aligned} |\tau(\hat{z}) - \tau(\hat{z}')| &< |\tau(\hat{z}) - \tau(\hat{z}_M)| + |\tau(\hat{z}_M) - \tau(\hat{z}''_M)| + |\tau(\hat{z}''_M) - \tau(\hat{z}'_M)| + |\tau(\hat{z}'_M) - \tau(\hat{z}')| \\ &< 10b|\hat{z} - \hat{z}_M| + \varepsilon^2 + 10b|\hat{z}''_M - \hat{z}'_M| + 10b|\hat{z}'_M - \hat{z}'| \\ &< \varepsilon. \end{aligned}$$

□

As a consequence of Lemma 5.1 we have that for a sufficiently small  $\mathcal{U}$  we manage to make  $W'_1$  (the leaf of  $W'$  of generation 1) to be as close to  $W_1$  (the leaf of  $W$  of generation 1) as we want. This is important because the leaves of higher generations are defined by successive iterations of the first generation leaf. We also remark that by the rules of construction of

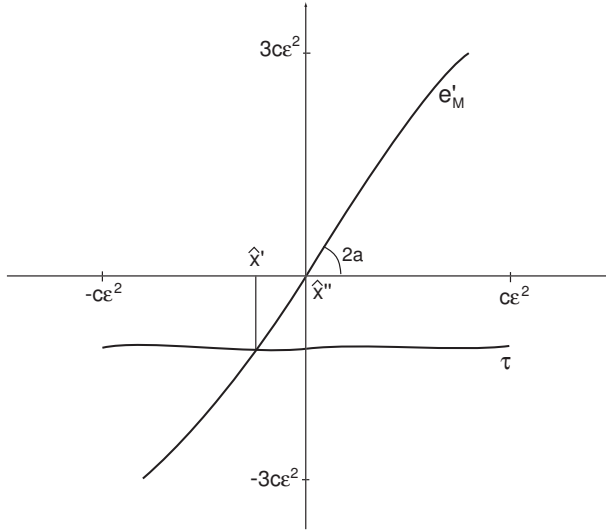
 FIGURE 2. Solution of  $e'_M(z) = \tau(z)$ 

the critical set we may use the argument of Lemma 5.1 to obtain proximity of the critical points up to generation 27. For higher generations we need the following lemma.

**Lemma 5.2.** *Let  $N \in \mathbb{N}$ ,  $(a, b) \in \mathcal{BC}$  and  $\varepsilon > 0$  be given. Assume there exists a neighborhood  $\mathcal{U}$  of  $(a, b)$  such that for each  $(a', b') \in \mathcal{U} \cap \mathcal{BC}$  and any critical point  $\hat{z}$  of  $f_{a,b}$  of generation  $g < N$ , there is a critical point  $\hat{z}'$  of  $f_{a',b'}$  of the same generation with  $|\hat{z} - \hat{z}'| < \varepsilon$ . If a critical point  $\hat{z}$  of  $f_{a,b}$  is created at step  $g + 1$ , then we may tighten  $\mathcal{U}$  so that a critical point  $\hat{z}'$  of generation  $g + 1$  is created for  $f_{a',b'}$  and  $|\hat{z} - \hat{z}'| < \varepsilon$ . Moreover, if  $\tau(\hat{z})$  and  $\tau(\hat{z}')$  are the unit vectors tangent to  $W$  and  $W'$  at  $\hat{z}$  and  $\hat{z}'$  respectively, then  $|\tau(\hat{z}) - \tau(\hat{z}')| < \varepsilon$ .*

*Proof.* As we are only interested in arbitrarily small  $\varepsilon$ , we may assume that  $\varepsilon < b^N$ . Suppose that a critical point  $\hat{z}$  of generation  $g + 1$  is created for  $f_{a,b}$ . Then, by the rules of construction of critical points, there are  $z = (x, y)$  lying in a  $C^2(b)$  segment  $\gamma \subset W$  of generation  $g + 1$  with  $\gamma$  extending beyond  $2\rho^{g+1}$  to each side of  $z$  and a critical point  $\tilde{z} = (x, \tilde{y})$  of generation not greater than  $g$  such that  $|z - \tilde{z}| < b^{(g+1)/540}$ . Moreover,  $|\hat{z} - z| < |z - \tilde{z}|^{1/2}$ .

Taking  $\gamma$  as a compact disk of  $W$ , there is a neighborhood  $\mathcal{U}$  of  $(a, b)$  such that for every  $(a', b') \in \mathcal{U}$  we can find a disk  $\gamma' \subset W'$  of generation  $g + 1$  which is  $\varepsilon^2$ -close to  $\gamma$  in the  $C^r$ -topology. It is clear that  $\gamma'$  is a  $C^2(b)$  curve. Our aim is to show that a critical point  $\hat{z}'$  of  $f_{a',b'}$  and generation  $g + 1$  is created in the segment  $\gamma'$  with  $|\hat{z} - \hat{z}'| < \varepsilon$ .

By the inductive hypothesis there is  $\tilde{z}' = (\tilde{x}', \tilde{y}')$  a critical point of  $f_{a',b'}$  such that  $|\tilde{z} - \tilde{z}'| < \varepsilon$ . Let  $z' = (\tilde{x}', y')$  belonging to  $\gamma'$ . Since  $\gamma'$  is  $\varepsilon^2$ -close to  $\gamma$  in the  $C^r$  topology and  $\varepsilon < b^N$ , which is completely insignificant when compared to  $\rho^{g+1} < \rho^N$  (recall that  $\rho \gg b$ ), we may assume that  $\gamma'$  extends more than  $2\rho^{g+1}$  to both sides of  $z'$ . Moreover,

letting  $\zeta' = (x, \eta') \in \gamma'$  we have

$$\begin{aligned} |\tilde{z}' - z'| &< |\tilde{z}' - \tilde{z}| + |\tilde{z} - z| + |z - \zeta'| + |\zeta' - z'| \\ &< \varepsilon + b^{\frac{g+1}{540}} + 2\varepsilon^2 + 2\varepsilon \\ &\lesssim b^{\frac{g+1}{540}}, \end{aligned}$$

where we used the fact that  $\varepsilon < b^N \ll b^{\frac{N}{540}} < b^{\frac{g+1}{540}}$  (see Figure 3). By the rules of

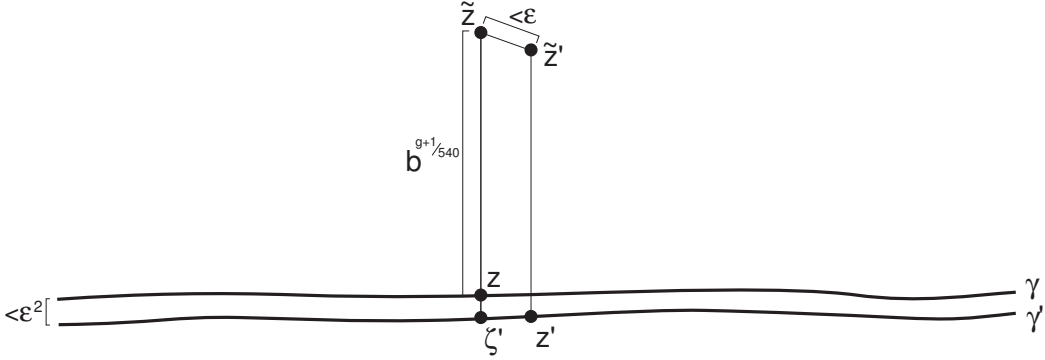

FIGURE 3. Possible relative position of the critical points

construction of critical points, a unique critical point  $\hat{z}'$  of generation  $g + 1$  is created in the segment  $\gamma'$ . We are left to show that  $|\hat{z} - \hat{z}'| < \varepsilon$ . For that we repeat the argument in the proof of Lemma 5.1.  $\square$

**Proposition 5.3.** *Let  $N \in \mathbb{N}$ ,  $(a, b) \in \mathcal{BC}$  and  $\varepsilon > 0$  be given. There is a neighborhood  $\mathcal{U}$  of  $(a, b)$  such that if  $(a', b') \in \mathcal{U} \cap \mathcal{BC}$  then, for any critical point  $\hat{z}$  of  $f_{a,b}$  of generation smaller than  $N$ , there is a critical point  $\hat{z}'$  of  $f_{a',b'}$  of the same generation such that  $|\hat{z} - \hat{z}'| < \varepsilon$ . Moreover if  $\tau(\hat{z})$  and  $\tau(\hat{z}')$  are the unit vectors tangent to  $W$  and  $W'$  at  $\hat{z}$  and  $\hat{z}'$  respectively, then  $|\tau(\hat{z}) - \tau(\hat{z}')| < \varepsilon$ .*

*Proof.* The proof is just a matter of collecting the information in the Lemmas 5.1 and 5.2 and organize it in a finite step induction scheme.

- (1) First obtain the proximity of the critical points of generation 1, which has already been done in Lemma 5.1.
- (2) Then realize that the same argument in the proof of Lemma 5.1 also gives the proximity of the  $2^{26}$  critical points of generation smaller than 27. (See the rules of construction of critical points in Subsection 3.4.1).
- (3) Apply the inductive step stated in Lemma 5.2 to obtain the proximity of critical points of higher and higher generation.
- (4) Stop the process when the proximity of all critical points of generation smaller than  $N$  is achieved.

Naturally every time we apply Lemma 5.2 to increase the generation level for which the conclusion of the proposition holds, we may need to decrease the size of the neighborhood  $\mathcal{U}$ . However, because the number of critical points of a given generation is finite and the statement of the proposition is up to generation  $N$ , at the end we still obtain a neighborhood containing a non-degenerate ball around  $(a, b)$  where the proposition holds.  $\square$

6. PROXIMITY OF LEADING CANTOR SETS

Attending to Lemma 5.1, we may assume that  $\Omega_0 = \Omega'_0$ . Let  $h, h' : \Omega_0 \rightarrow \mathbb{R}$  be functions whose graphs are the leaves of first generation  $W_1$  and  $W'_1$  respectively, when restricted to the set  $\Omega_0 \times \mathbb{R}$ . Given an interval  $I \subset \Omega_0$  the segments  $\omega = H(I)$  and  $\omega' = H'(I)$  are respectively the subsets of  $W_1$  and  $W'_1$  which correspond to the images in the graph of  $h$  and  $h'$  of the interval  $I$ . Accordingly, if  $x \in \Omega_0$  then  $z = H(x) = (x, h(x))$  and  $z' = H'(x) = (x, h'(x))$ . See Figure 4.

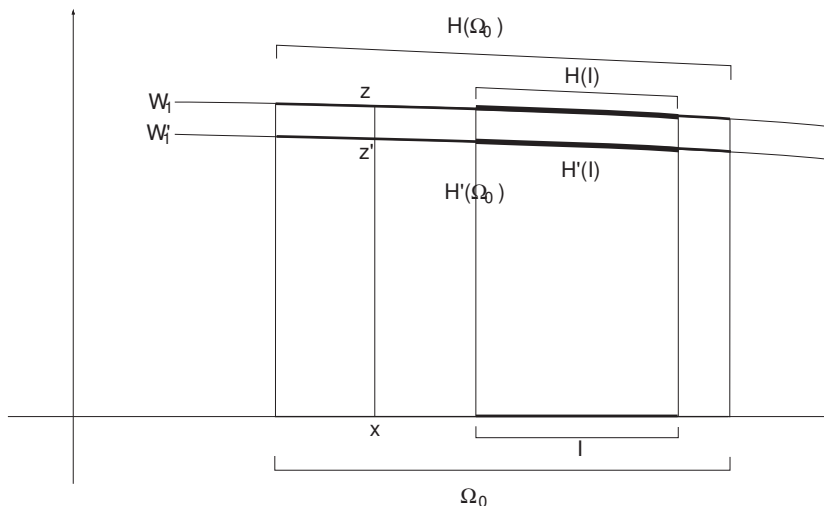

FIGURE 4

Our goal in this section is to show the proximity of the Cantor sets  $\Omega_\infty$  for close Benedicks-Carleson parameters. More precisely, given any  $\varepsilon > 0$  we will exhibit a neighborhood  $\mathcal{U}$  of  $(a, b)$  such that  $|\Omega_\infty \Delta \Omega'_\infty| < \varepsilon$  for all  $(a', b') \in \mathcal{U} \cap \mathcal{BC}$ , where  $\Delta$  represents symmetric difference between two sets. In the process, we make a modification in the first steps of the procedure described in Subsection 4.1 to build  $\Omega'_\infty$ , which carries only minor differences with respect to the set we would obtain if we were to follow the rules strictly. Ultimately, this affects the construction of the horseshoes  $\Lambda'$ . However, the horseshoes are not uniquely determined and we will evince that the modifications introduced leave unchanged the properties that they are supposed to have.

**Lemma 6.1.** *Given  $\varepsilon > 0$ , there exists  $N_1 \in \mathbb{N}$  such that  $|\Omega_n \setminus \Omega_\infty| < \varepsilon$  for every  $(a, b) \in \mathcal{BC}$  and  $n \geq N_1$ .*

*Proof.* This is a consequence of [BY00, Lemma 4] where it is proved that

$$\frac{|\Omega_{n-1} \setminus \Omega_n|}{|\Omega_{n-1}|} \leq C_1 \delta^{1-3\beta} e^{-\alpha(1-3\beta)n}. \quad (6.1)$$

This inequality follows from the fact that any connected component  $\omega \in H(\Omega_{n-1})$  grows to reach a length  $|f^n(\omega)| \geq \delta^{3\beta} e^{-3\alpha\beta n}$ , while the subsegment of  $f^n(\omega)$  to be deleted in the construction of  $\Omega_n$  has length at most  $4\delta e^{-\alpha n}$ ; then, simply take bounded distortion into consideration.

From (6.1) one easily gets

$$\begin{aligned} |\Omega_n \setminus \Omega_\infty| &= \sum_{j=0}^{+\infty} |\Omega_{n+j} \setminus \Omega_{n+j+1}| \\ &\leq C_1 \delta^{1-3\beta} \sum_{j=1}^{+\infty} e^{-\alpha(1-3\beta)(n+j)} |\Omega_{n+j-1}| \\ &\leq C_1 \delta^{1-3\beta} |\Omega_n| \sum_{j=1}^{+\infty} e^{-\alpha(1-3\beta)(n+j)} \\ &\leq C_1 \delta^{1-3\beta} \frac{e^{-\alpha(1-3\beta)(n+1)}}{1 - e^{-\alpha(1-3\beta)}} \end{aligned}$$

Hence, choose  $N_1$  sufficiently large so that

$$C_1 \delta^{1-3\beta} \frac{e^{-\alpha(1-3\beta)(N_1+1)}}{1 - e^{-\alpha(1-3\beta)}} < \varepsilon.$$

□

Observe that, as a consequence of the unstable manifold theorem, for every  $\varepsilon > 0$  and  $n \in \mathbb{N}$ , there exists a neighborhood  $\mathcal{U}$  of  $(a, b)$  such that for every  $(a', b') \in \mathcal{U}$  we have

$$\max \left\{ \|H - H'\|_r, \|f_{a,b} \circ H - f_{a',b'} \circ H'\|_r, \dots, \|f_{a,b}^n \circ H - f_{a',b'}^n \circ H'\|_r \right\} < \varepsilon, \quad (6.2)$$

where  $r \geq 2$  and  $\|\cdot\|_r$  is the  $C^r$ -norm in  $\Omega_0$ . In what follows  $\Omega_\infty = \bigcap_{n \in \mathbb{N}} \Omega_n$  is built as described in Section 4.1 for  $f = f_{a,b}$ .

**Lemma 6.2.** *Let  $n \in \mathbb{N}$  and  $(a, b) \in \mathcal{BC}$  be given and  $I$  be a connected component of  $\Omega_{n-1}$ . Suppose  $f_{a,b}^n(H(I))$  intersects  $(-\delta, \delta) \times \mathbb{R}$ . There is a neighborhood  $\mathcal{U}$  of  $(a, b)$  such that for every  $(a', b') \in \mathcal{U} \cap \mathcal{BC}$  and  $x \in I \cap \Omega_n$ , if  $f_{a,b}^n(H(x)) \in (-\delta, \delta) \times \mathbb{R}$  and  $\hat{z}$  is a suitable binding critical point, then there exists a binding critical point  $\hat{z}'$  of  $f_{a',b'}$  close to  $\hat{z}$  suitable for  $f_{a',b'}^n(H'(x))$  and  $|f_{a',b'}^n(H'(x)) - \hat{z}'| \gtrsim \delta e^{-\alpha n}$ .*

*Proof.* Let  $\tilde{I} = I \cap \Omega_n$  and  $\mathcal{U}$  be a neighborhood of  $(a, b)$  such that Proposition 5.3 applies up to  $n$  with  $b^{2n}$  in the place of  $\varepsilon$  and equation (6.2) also holds with  $b^{4n}$  in the place of  $\varepsilon$ . Then there is a critical point  $\hat{z}'$  of  $f_{a',b'}$  such that  $|\hat{z} - \hat{z}'| < b^{2n}$  and  $\|f_{a,b}^n \circ H|_{\tilde{I}} - f_{a',b'}^n \circ H'|_{\tilde{I}}\|_r < b^{4n}$ . We only need to prove that this  $\hat{z}'$  is a suitable binding point for  $f_{a',b'}^n(z')$  and that  $|f_{a',b'}^n(z') - \hat{z}'| \gtrsim \delta e^{-\alpha n}$ . In order to verify the suitability of  $\hat{z}'$  we have to check that



- (1)  $f_{a',b'}^n(z')$  is in tangential position with respect to  $\hat{z}'$ ;
- (2)  $Df_{a',b'}^n(z')\tau(z')$  splits correctly with respect to the contracting field around  $\hat{z}'$ .

The strategy is to show that  $|f_{a,b}^n(z) - \hat{z}| = |f_{a',b'}^n(z') - \hat{z}'| + \mathcal{O}(b^{2n})$ . Then, because  $f^n(z)$  is in tangential position with respect to  $\hat{z}$  and  $b^{2n} \ll \delta e^{-\alpha n} \leq |f^n(z) - \hat{z}|$ , we conclude the tangential position for  $f_{a',b'}^n(z')$  with respect to  $\hat{z}'$ . As to the correct splitting, we know that  $|Df^n(z)\tau(z) - (Df_{a',b'}^n(z')\tau(z'))| < b^{4n}$  and  $Df^n(z)\tau(z)$  makes an angle with the relevant contracting field of approximately  $(2a \pm 1)|f^n(z) - \hat{z}|$ . Finally, since  $|f^n(z) - \hat{z}| = |f_{a',b'}^n(z') - \hat{z}'| + \mathcal{O}(b^{2n})$  and  $b^{2n} \ll (2a \pm 1)|f^n(z) - \hat{z}|$  we obtain the desired result.

Let us start by proving (1). Observe that

$$\begin{aligned} |f_{a,b}^n(z) - \hat{z}| &\leq |f_{a,b}^n(z) - f_{a',b'}^n(z')| + |f_{a',b'}^n(z') - \hat{z}'| + |\hat{z} - \hat{z}'| \\ &\leq \|f_{a,b}^n \circ H|_{\bar{l}} - f_{a',b'}^n \circ H'|_{\bar{l}}\|_r + |f_{a',b'}^n(z') - \hat{z}'| + b^{2n} \\ &\leq |f_{a',b'}^n(z') - \hat{z}'| + 2b^{2n}. \end{aligned}$$

Interchanging  $z$  with  $z'$  we easily get  $|f_{a',b'}^n(z') - \hat{z}'| \leq |f_{a,b}^n(z) - \hat{z}| + 2b^{2n}$  which allows us to write  $|f_{a',b'}^n(z') - \hat{z}'| = |f_{a,b}^n(z) - \hat{z}| + \mathcal{O}(b^{2n})$ . Consider now  $s$  and  $s'$  the lines through  $\hat{z}$  and  $\hat{z}'$  with slopes  $\tau(\hat{z})$  and  $\tau(\hat{z}')$  respectively. By Proposition 5.3 we have  $|\hat{z} - \hat{z}'| < b^{2n}$  and also  $|\tau(\hat{z}) - \tau(\hat{z}')| < b^{2n}$ . Thus, when restricted to the set  $[-1, 1] \times \mathbb{R}$  we have  $\|s - s'\|_r < \mathcal{O}(b^{2n})$ . Let  $\text{dist}(z, s)$  denote the distance from the point  $z$  to the segment  $s \cap [-1, 1] \times \mathbb{R}$ . Then

$$\begin{aligned} \text{dist}(f_{a,b}^n(z), s) &\leq |f_{a,b}^n(z) - f_{a',b'}^n(z')| + \text{dist}(f_{a',b'}^n(z'), s) \\ &\leq |f_{a,b}^n(z) - f_{a',b'}^n(z')| + \|s - s'\|_r + \text{dist}(f_{a',b'}^n(z'), s') \\ &\leq \text{dist}(f_{a',b'}^n(z'), s') + \mathcal{O}(b^{2n}) \end{aligned}$$

Similarly we get  $\text{dist}(f_{a',b'}^n(z'), s') \leq \text{dist}(f_{a,b}^n(z), s) + \mathcal{O}(b^{2n})$ , and so

$$\text{dist}(f_{a',b'}^n(z'), s') = \text{dist}(f_{a,b}^n(z), s) + \mathcal{O}(b^{2n}).$$

Now, since  $f^n(z)$  is in tangential position with respect to  $\hat{z}$ , then

$$\text{dist}(f_{a,b}^n(z), s) < c|f_{a,b}^n(z) - \hat{z}|^2,$$

where  $c \ll 2a$ . Besides,  $|f_{a',b'}^n(z') - \hat{z}'|^2 = (|f_{a,b}^n(z) - \hat{z}| + \mathcal{O}(b^{2n}))^2 = |f_{a,b}^n(z) - \hat{z}|^2 + \mathcal{O}(b^{2n})$  because  $b^{2n} \ll \delta e^{-\alpha n} \leq |f_{a,b}^n(z) - \hat{z}|$ . Consequently

$$\text{dist}(f_{a',b'}^n(z'), s') < c|f_{a',b'}^n(z') - \hat{z}'|^2 + \mathcal{O}(b^{2n}),$$

which again by the insignificance of  $b^{2n}$  relative to  $|f_{a',b'}^n(z') - \hat{z}'|$  implies that  $f_{a',b'}^n(z')$  is in tangential position with respect to  $\hat{z}'$ .

Concerning (2), notice that if  $(a', b')$  is sufficiently close to  $(a, b)$ , then

$$|Df_{a,b}^n(z)\tau(z) - Df_{a',b'}^n(z')\tau(z')| \leq \|f_{a,b}^n \circ H|_{\bar{l}} - f_{a',b'}^n \circ H'|_{\bar{l}}\|_r < b^{4n}.$$

Let  $l$  and  $l'$  denote the lengths of the fold periods for  $z$  and  $z'$ . Take  $m$  and  $m'$  such that  $(5b)^m \leq |z - \hat{z}| \leq (5b)^{m-1}$  and  $(5b)^{m'} \leq |z' - \hat{z}'| \leq (5b)^{m'-1}$  respectively. Since  $|z' - \hat{z}'| = |z - \hat{z}| + \mathcal{O}(b^{2n})$  and  $b^{2n}$  is negligible when compared to  $|z - \hat{z}|$ , we may assume

that  $m = m'$ . We know that  $|\tau(f_{a,b}^n(z)) - e_l(z)| \approx (2a \pm 1)|z - \hat{z}|$ . Since  $l \geq 2m$ , property (4) of Section 3.3 leads to  $|e_l(z) - e_{2m}(z)| = \mathcal{O}(b^{2m})$ . As a consequence we have

$$|\tau(f_{a,b}^n(z)) - e_{2m}(z)| = |\tau(f_{a,b}^n(z)) - e_l(z)| + \mathcal{O}(b^{2m}) \approx (2a \pm 1)|z - \hat{z}|,$$

because  $|z - \hat{z}| \geq (5b)^m \gg b^m \gg b^{2m}$ .

Observe that  $|\tau(f_{a,b}^n(z)) - \tau(f_{a',b'}^n(z'))| < b^{2n}$  because  $|Df_{a,b}^n(z)\tau(z)| > \delta e^{c2n}$ , by (EE), and  $|Df_{a,b}^n(z)\tau(z) - Df_{a',b'}^n(z')\tau(z')| < b^{4n}$ . If necessary, we tighten  $\mathcal{U}$  in order to guarantee  $|e_{2m}(z) - e'_{2m}(z')| < b^{2n}$ . Since  $b^{2n} \ll |z' - \hat{z}'|$  we conclude that

$$|\tau(f_{a',b'}^n(z')) - e'_{2m}(z')| = |\tau(f_{a,b}^n(z)) - e_{2m}(z)| + \mathcal{O}(b^{2n}) \approx (2a \pm 1)|z' - \hat{z}'|.$$

Finally, a similar argument allows us to obtain

$$|\tau(f_{a',b'}^n(z')) - e'_l(z')| = |\tau(f_{a',b'}^n(z')) - e'_{2m}(z')| + \mathcal{O}(b^{2m}) \approx (2a \pm 1)|z' - \hat{z}'|,$$

which gives the correct splitting of the vector  $(Df_{a',b'}^n(z'))\tau(z')$  with respect to the critical point  $\hat{z}'$ .  $\square$

Now we will show that if we change the rules of construction of  $\Omega'_\infty$  in the first  $N$  iterates by choosing a convenient binding critical point at each return happening before  $N$  we manage to have  $\Omega_N = \Omega'_N$  as long as  $(a', b')$  is sufficiently close to  $(a, b)$ .

Before proceeding let us clarify the equality  $\Omega'_n = \Omega_n$  for  $n \leq N$ . As mentioned in Remark 4.3, the procedure leading to  $\Omega_\infty$  is not unique. Thus, we have some freedom in the construction of  $\Omega'_\infty$  as long as we guarantee the slow approximation to the critical set and the expansion along the tangent direction to  $W$ .

Take  $(a', b') \in \mathcal{U} \cap \mathcal{BC}$ , where  $\mathcal{U}$  is a small neighborhood of  $(a, b)$ . Applying the procedure of [BY00] described in Section 4.1 we may build a sequence of sets  $\Omega'_0 \supset \Omega'_1 \supset \dots$  to obtain  $\Omega'_\infty = \bigcap_{j \in \mathbb{N}_0} \Omega'_j$ . From Lemmas 5.1 and 6.2 we know that, given  $N$  and  $j \leq N$ , the set  $\Omega_j$  is a good approximation of  $\Omega'_j$ . We propose a modification on the first  $N$  steps in the construction of  $\Omega'_\infty$ : consider  $\Omega'_n = \Omega_n$  for all  $n \leq N$ ; afterwards make the exclusions of points from  $\Omega_N$  according to the original procedure. This way, we produce a sequence of sets  $\Omega_0 \supset \dots \supset \Omega_N \supset \Omega'_{N+1} \supset \dots$  which we intersect to obtain  $\Omega'_\infty$ . We will show that the points in  $\Omega'_\infty$  have slow approximation to the critical set and expansion along the tangent direction of  $W'$  for the dynamics  $f_{a',b'}$ .

When we perturb a parameter  $(a, b) \in \mathcal{BC}$  and change the rules of construction of  $\Omega'_n$  for a close parameter  $(a', b') \in \mathcal{U} \cap \mathcal{BC}$ , in the sense mentioned above, we may need to weaken the condition (SA) and introduce condition (SA)' which is defined as (SA) except for the replacement of  $\delta$  by  $\delta/2$ . This way we guarantee the validity of (SA)' for every  $(a', b')$  in a sufficiently small neighborhood  $\mathcal{U}$  of  $(a, b)$  as stated in next lemma.

**Lemma 6.3.** *Let  $(a, b) \in \mathcal{BC}$  and  $n \in \mathbb{N}$  be given. There is a neighborhood  $\mathcal{U}$  of  $(a, b)$  such that for all  $(a', b') \in \mathcal{U} \cap \mathcal{BC}$  we may take  $\Omega'_j = \Omega_j$  for all  $j \leq n$  and ensure that (SA)' holds for all  $j \leq n$ , for the dynamics  $f_{a',b'}$ .*

*Proof.* If  $\mathcal{U}$  is sufficiently small, then by Proposition 5.3 we have that (SA)' holds for  $n = 0$ , in  $H'(\Omega_0)$ , for the dynamics  $f_{a',b'}$ . Let us suppose that (SA)' holds in  $H'(\Omega_{n-1})$ , for  $f_{a',b'}$  and  $j \leq n - 1 < N$ . This is to say that for all  $x \in \Omega_{n-1}$  the  $f_{a',b'}$  orbit of  $z' = H'(x)$  is

controlled up to  $n - 1$  and at each return  $k \leq n - 1$ , if  $\hat{z}'$  denotes a suitable binding critical point, then  $|f_{a',b'}^k(z') - \hat{z}'| \geq \delta e^{-\alpha k}/2$ .

Our aim is to show that by tightening  $\mathcal{U}$ , if necessary, this last statement remains true for  $n$ . Let  $I \subset \Omega_{n-1}$  be a connected component and  $\tilde{I} = I \cap \Omega_n$ . Then, by Lemma 6.2, we can tighten  $\mathcal{U}$ , so that for all  $x \in \Omega_{n-1}$ , the orbit of  $z' = H'(x)$  under  $f_{a',b'}$  is controlled up to  $n$ . Moreover, if  $n$  is a return time for  $z'$ , and  $\hat{z}'$  is a suitable binding point for  $f_{a',b'}^n(z')$ , then  $|f_{a',b'}^n(z') - \hat{z}'| \geq \delta e^{-\alpha n}/2$ . Since each  $\Omega_n$  has a finite number of connected components and we only wish to carry on this procedure up to  $N$ , then at the end we still obtain a neighborhood  $\mathcal{U}$  of  $(a, b)$ .  $\square$

Thus, for every  $(a', b') \in \mathcal{U} \cap \mathcal{BC}$ , where  $\mathcal{U}$  is given by Lemma 6.3, we have a sequence of sets  $\Omega_0 \supset \dots \supset \Omega_N$  such that  $(SA)'$  holds for every  $z' = H'(x)$  with  $x \in \Omega_N$  and  $n \leq N$ . At this point we proceed with the method described in Section 4 and make exclusions out of  $\Omega_N$  to obtain a sequence  $\Omega_0 \supset \dots \supset \Omega_N \supset \Omega'_{N+1} \supset \dots$  whose intersection we denote by  $\Omega'_\infty$ . Hence, every point in  $H'(\Omega'_\infty)$  satisfies  $(SA)$  for every  $n > N$ .

**Corollary 6.4.** *Let  $(a, b) \in \mathcal{BC}$  and  $\varepsilon > 0$  be given. There exists a neighborhood  $\mathcal{U}$  of  $(a, b)$  so that  $|\Omega_\infty \Delta \Omega'_\infty| < \varepsilon$  for each  $(a', b') \in \mathcal{U} \cap \mathcal{BC}$ .*

*Proof.* We appeal to Lemma 6.1 and find  $N_1 = N_1(\varepsilon)$  such that  $|\Omega_{N_1} \setminus \Omega_\infty| < \varepsilon/2$ . Observe that, using Lemma 6.3, the same  $N_1$  allows us to write that  $|\Omega_{N_1} \setminus \Omega'_\infty| < \varepsilon/2$  for all  $(a', b') \in \mathcal{U} \cap \mathcal{BC}$ . So, we have  $|\Omega_\infty \Delta \Omega'_\infty| \leq |\Omega_{N_1} \Delta \Omega_\infty| + |\Omega_{N_1} \Delta \Omega'_\infty| < \varepsilon$ .  $\square$

## 7. PROXIMITY OF STABLE CURVES

So far we have managed to prove proximity of the horseshoes in the horizontal direction. The goal of this section is to show the closeness of the stable curves. The main result of this section is Proposition 7.3.

Recall that each long stable curve is obtained as a limit of “temporary stable curves”,  $\gamma_n$ , as described in Section 4.2. In order to obtain proximity of long stable curves for close Benedicks-Carleson dynamics we must produce first an integer  $N_2$  such that the approximate stable curves  $\gamma_{N_2}$  are sufficiently close to the corresponding stable curves  $\gamma^s$ , regardless of the parameter  $(a, b) \in \mathcal{BC}$ . This is accomplished through Lemma 7.1. Therefore, in Proposition 7.3 we obtain the proximity of the “temporary stable curves”  $\gamma_{N_2}$  for close Benedicks-Carleson parameters and deduce in this way the desired proximity of the long stable curves.

We use the notation  $\gamma_n(\zeta)(t)$  or its shorter version,  $\gamma_n^t(\zeta)$ , for the solution of the equation  $\dot{z} = e_n(z)$  with initial condition  $\gamma_n(\zeta)(0) = \gamma_n^0(\zeta) = \zeta$ . Recall that  $\|e_n\| = 1$  and  $\gamma_n(\zeta)$  is an  $e_n$ -integral curve of length  $20b$  centered at  $\zeta$ . So the natural range of values for  $t$  is  $[-10b, 10b]$ .

**Lemma 7.1.** *Let  $(a, b) \in \mathcal{BC}$  and  $n \in \mathbb{N}$  be given. Consider a connected component  $\omega \subset H(\Omega_{n-1})$  and the rectangle  $Q_{n-1}(\omega)$  foliated by the curves  $\gamma_n$ . Then the width of the rectangle  $Q_{n-1}(\omega)$  is at most  $4\delta^{-1}e^{-c_2n}$ .*

*Proof.* By the derivative estimate in Subsection 3.6.1, for all  $z \in \omega$  we have

$$|Df^n(z)\tau(z)| > \delta e^{c_2 n}.$$

Since  $\omega$  is a connected component of  $H(\Omega_{n-1})$  we have that  $|f^n(\omega)| < 2$ . As a consequence,  $|\omega| < 2\delta^{-1}e^{-c_2 n}$ . Observe that this argument also gives that if  $z \in H(\Omega_\infty)$  and  $\omega_j$  denotes the connected component of  $H(\Omega_j)$  containing  $z$  then  $\cap_j \omega_j = \{z\}$ . Let  $z^+$  and  $z^-$  denote respectively the right and left endpoints of  $\omega$ . Given  $t \in [-10b, 10b]$

$$\begin{aligned} |\gamma_n^t(z^+) - \gamma_n^t(z^-)| &\leq \left| z^+ + \int_0^t e_n(\gamma_n^r(z^+)) dr - z^- - \int_0^t e_n(\gamma_n^r(z^-)) dr \right| \\ &\leq |z^+ - z^-| + \int_0^t |e_n(\gamma_n^r(z^+)) - e_n(\gamma_n^r(z^-))| dr \\ &\leq |z^+ - z^-| + 5 \int_0^t |\gamma_n^r(z^+) - \gamma_n^r(z^-)| dr, \text{ by (3) of Section 3.3} \\ &\leq |z^+ - z^-| e^{5|t|}, \text{ by a Gronwall type inequality} \\ &\leq |z^+ - z^-| e^{50b} < 2|z^+ - z^-| = 2|\omega| \end{aligned}$$

Thus, the width of the rectangle  $Q_{n-1}(\omega)$  is at most  $4\delta^{-1}e^{-c_2 n}$ .  $\square$

We will use the following notation for parameters  $(a', b')$  close to  $(a, b)$ . For any  $n \in \mathbb{N}$  and  $z' \in \omega'_n \subset H'(\Omega'_n)$ , we denote by  $\gamma'_{n+1}(z')$  the  $e'_{n+1}$ -integral curve of length  $20b$  centered at  $z'$ . Given  $n \in \mathbb{N}$ , for any connected component  $\omega' \subset H'(\Omega'_n)$  we denote by  $Q_n(\omega') = \cup_{z' \in \omega'} \gamma'_{n+1}(z')$  the rectangle foliated by the curves  $\gamma'_{n+1}(z')$ . We define  $Q_n^1(\omega')$  as a  $(Cb)^{n+1}$ -neighborhood of  $Q_n(\omega')$  in  $\mathbb{R}^2$ . Finally, given  $n \in \mathbb{N}$  and any interval  $\omega \subset H(\Omega_n)$ , we denote by  $Q_n^2(\omega)$  a  $2(Cb)^{n+1}$ -neighborhood of  $Q_n(\omega)$ .

**Lemma 7.2.** *Let  $(a, b) \in \mathcal{BC}$ ,  $n \in \mathbb{N}$ ,  $\varepsilon > 0$  be given, and fix a connected component  $I$  of  $\Omega_{n-1}$ . Then there is a neighborhood  $\mathcal{U}$  of  $(a, b)$  such that  $e_n, e'_n$  are defined in  $Q_{n-1}^2(H(I))$  and for every  $x \in I$*

$$\|\gamma_n(H(x)) - \gamma'_n(H'(x))\|_0 < \varepsilon.$$

*Moreover, for every interval  $J \subset I$  we have that  $Q_{n-1}^2(H(J))$  contains  $Q_{n-1}^1(H'(J))$ .*

*Proof.* As we are only interested in arbitrarily small  $\varepsilon$ , we may assume that  $\varepsilon < b^{2n}$ . Take the neighborhood  $\mathcal{U}$  of  $(a, b)$  given by Lemma 6.3 applied to  $n$ . Within  $\mathcal{U} \cap \mathcal{BC}$ , the set  $\Omega'_\infty$  is built out of  $\Omega_n$ , in the usual way.

Consider the sequence  $I_0 \supset \dots \supset I_j \supset \dots \supset I_n = I$  of the connected components (intervals)  $I_j$  of  $\Omega_j$  containing  $I$ . For every  $j \leq n$ , let  $\omega_j = H(I_j)$  and  $\omega'_j = H'(I_j)$ . We will use a finite inductive scheme such that at step  $j$ , under the hypothesis that  $e_j$  and  $e'_j$  are both defined in  $Q_{j-2}(\omega_{j-1})$ , we tighten  $\mathcal{U}$  (if necessary) so that for all  $x \in I_{j-1}$  we have  $\gamma_j(z)$   $\varepsilon$ -close to  $\gamma'_j(z')$  in the  $C^0$  topology, where  $z = H(x)$  and  $z' = H'(x)$ , which implies that  $Q_{j-1}^2(\omega_j)$  contains  $Q_{j-1}^1(\omega'_j)$ . This way we conclude that both  $e_{j+1}$  and  $e'_{j+1}$  are defined in the set  $Q_{j-1}^2(\omega_j)$ , which makes our hypothesis true for step  $j+1$ . After  $n$  steps we still have a vicinity  $\mathcal{U}$  of  $(a, b)$  and  $\gamma_n(z)$  is  $\varepsilon$   $C^0$ -close to  $\gamma'_n(z')$ .

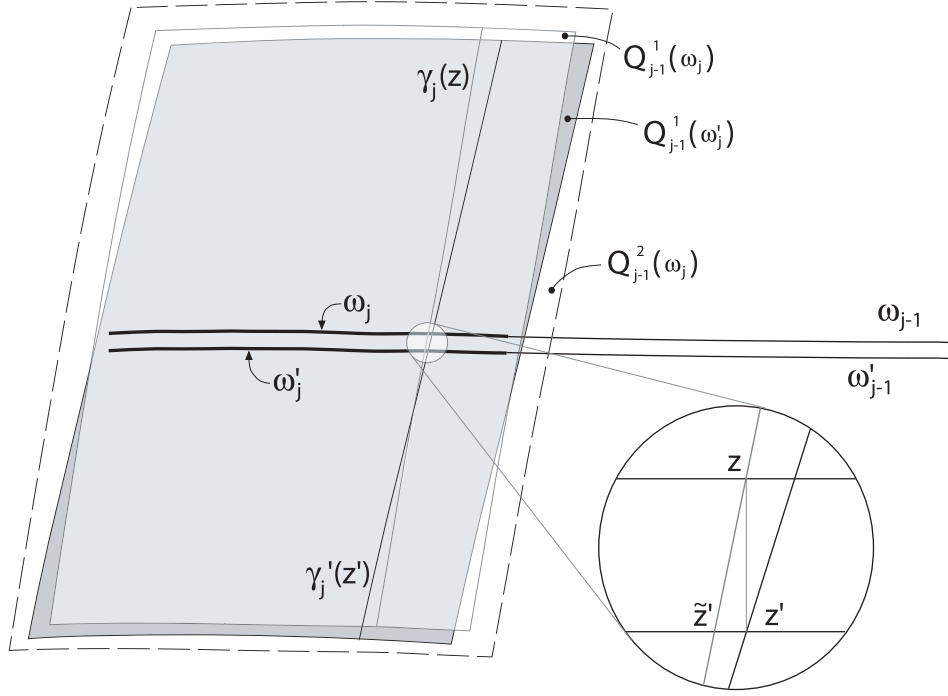

FIGURE 5

We know that  $e_1$  and  $e'_1$  are defined everywhere in  $\mathbb{R}^2$ , which makes our hypothesis true at the first step.

Suppose now, by induction, that at step  $j$  we know that  $e_j$  and  $e'_j$  are both defined in  $Q_{j-2}^2(\omega_{j-1})$ , which contains both  $Q_{j-2}^1(\omega_{j-1})$  and  $Q_{j-2}^1(\omega'_{j-1})$ . Let  $\mathcal{U}$  be sufficiently small so that for all  $(a', b') \in \mathcal{U} \cap \mathcal{BC}$ , we have  $\|H - H'\|_r < \varepsilon^3$  and  $|e_j(z) - e'_j(z)| < \varepsilon$ , for every  $z \in Q_{j-2}^2(\omega_{j-1})$ . Since  $Q_{j-1}^1(\omega_{j-1}) \subset Q_{j-2}^1(\omega_{j-1})$  and  $Q_{j-1}^1(\omega'_{j-1}) \subset Q_{j-2}^1(\omega'_{j-1})$  (see (4.1)), the curves  $\gamma_j(z)$  and  $\gamma_j(z')$  never leave the set  $Q_{j-2}^2(\omega_{j-1})$ , for every  $z \in \omega_{j-1}$  and  $z' \in \omega'_{j-1}$ .

Let  $\{\tilde{z}'\} = \gamma_j(z) \cap W'_1$ ; since  $\|H - H'\|_r < \varepsilon^3$  then  $|\tilde{z}' - z| < \varepsilon^2$ ,  $|\tilde{z}' - z'| < \varepsilon^2$  (see Figure 5). Using the Lipschitzness of the fields  $e_j$  and  $e'_j$  (property (3) in Section 3.3), the continuity of flows with initial conditions and the continuity of flows as functions of the vector field (see for example [HS74]) we have for all  $t$

$$\begin{aligned} |\gamma_j(\tilde{z}')(t) - \gamma'_j(z')(t)| &\leq |\gamma_j(\tilde{z}')(t) - \gamma'_j(\tilde{z}')(t)| + |\gamma'_j(\tilde{z}')(t) - \gamma'_j(z')(t)| \\ &\leq \frac{\varepsilon}{2a + \mathcal{O}(b)}(e^{5|t|} - 1) + |\tilde{z}' - z'|e^{5|t|} \\ &\leq \frac{\varepsilon}{3}e^{50b}50b + 2\varepsilon^2 < \varepsilon \end{aligned}$$

Thus  $\|\gamma_j(z) - \gamma'_j(z')\|_0 < \varepsilon$ . Moreover, since  $\varepsilon \ll (Cb)^j$ , we easily get that for any interval  $J \subset I_{j-1}$ , the rectangle  $Q_{j-1}^2(H(J))$  contains both  $Q_{j-1}^1(H(J))$  and  $Q_{j-1}^1(H'(J))$ .

From [BY00, Section 3.3] we know  $e_{j+1}$  is defined in a  $3(Cb)^j$ -neighborhood in  $\mathbb{R}^2$  of  $\gamma_j(z)$ , for every  $z \in \omega_j$ . Since the same applies to  $\gamma'_j(z')$  where  $z' \in \omega'_j$  and clearly  $\gamma_j(z)$  lies inside a  $(Cb)^j$ -neighborhood in  $\mathbb{R}^2$  of  $\gamma'_j(z')$  ( $\varepsilon \ll (Cb)^j$ ) then  $e'_{j+1}$  is defined in all points of  $\gamma_j(z)$ . This also implies that  $e'_{j+1}$  is defined in  $Q_{j-1}^2(\omega_j)$ . Thus applying the argument above  $n$  times we get that  $e_n$  and  $e'_n$  are defined in  $Q_{n-2}^2(\omega_{n-1})$  and for every  $z \in \omega_{n-1}$ ,  $z' = H'(H^{-1}(z)) \in \omega'_{n-1}$ ,

$$\|\gamma_n(z) - \gamma'_n(z')\|_0 < \varepsilon,$$

which gives that for any interval  $J \subset \Omega_{n-1}$  we have that  $Q_{n-1}^2(H(J))$  contains both  $Q_{n-1}^1(H(J))$  and  $Q_{n-1}^1(H'(J))$ , since  $\varepsilon \ll b^n$ .  $\square$

**Proposition 7.3.** *Let  $(a, b) \in \mathcal{BC}$  and  $\varepsilon > 0$  be given. There is a neighborhood  $\mathcal{U}$  of  $(a, b)$  such that for all  $(a', b') \in \mathcal{U} \cap \mathcal{BC}$  and  $x \in \Omega_\infty \cap \Omega'_\infty$ , we have that  $\gamma^s(H(x))$  and  $\gamma'^s(H'(x))$  are  $\varepsilon$ -close in the  $C^1$  topology.*

*Proof.* Choose  $N_2 \in \mathbb{N}$  large enough so that

$$4\delta^{-1}e^{-c_2N_2} + 4(Cb)^{N_2} < \frac{\varepsilon}{3} \quad (7.1)$$

By Lemma 7.1 the width of the rectangle  $Q_{N_2-1}^2(\omega_{N_2-1})$  is less than  $\frac{\varepsilon}{3}$ . This means that for every  $\zeta \in \omega_{N_2}$ , the curve  $\gamma_{N_2}(\zeta)$  is at least  $\frac{\varepsilon}{3}$ -close to  $\gamma^s(z)$  in the  $C^0$  topology. Note that the choice of  $N_2$  does not depend on the point  $z \in H(\Omega_\infty)$  taken, neither on the parameter  $(a, b) \in \mathcal{BC}$  in question.

Take the neighborhood  $\mathcal{U}$  of  $(a, b)$  to be such that Lemma 6.3 applies up to  $N_2$  and Lemma 7.2 applies with  $N_2$  replacing  $n$ . In particular, for parameters  $\mathcal{U} \cap \mathcal{BC}$ , the set  $\Omega'_\infty$  is built out of  $\Omega_{N_2}$ , in the usual way and  $Q_{N_2-1}^2(H(I))$  contains  $Q_{N_2-1}^1(H'(I))$  for every connected component  $I \subset \Omega_{N_2-1}$ . Moreover, for any  $x \in I$ ,  $\|\gamma_{N_2}(H(x)) - \gamma'_{N_2}(H'(x))\|_0 < b^{2N_2}$ .

Let  $x \in \Omega_\infty \cap \Omega'_\infty$  and consider the sequence  $I_0 \supset I_1 \supset \dots \supset I_j \supset \dots$  of the connected components (intervals)  $I_j$  of  $\Omega_j$  containing  $x$ . Let  $z = H(x)$ ,  $z' = H'(x)$  and, for every  $j < N_2$ , set  $\omega_j = H(I_j)$  and  $\omega'_j = H'(I_j)$ . Collecting all the information we get for any  $\zeta \in \omega_{N_2-1}$ ,  $\zeta' = H'(H^{-1}(\zeta)) \in \omega'_{N_2-1}$

$$\|\gamma^s(z) - \gamma'^s(z')\|_0 \leq \|\gamma^s(z) - \gamma_{N_2}(\zeta)\|_0 + \|\gamma_{N_2}(\zeta) - \gamma'_{N_2}(\zeta')\|_0 + \|\gamma'_{N_2}(\zeta') - \gamma'^s(z')\|_0 < \varepsilon.$$

So far we have proved  $C^0$ -closeness of the stable leaves. The fact that the fields  $e_n$  and  $e'_n$  are Lipschitz with uniform Lipschitz constant  $3 < 2a + \mathcal{O}(b) < 5$  allows us to improve the previous  $C^0$ -estimates to obtain  $C^1$ -estimates with little additional effort.  $\square$

## 8. PROXIMITY OF $s$ -SUBLATTICES AND RETURN TIMES

The purpose of this section is to obtain the proximity, for close-by Benedicks-Carleson dynamics, of the sets of points with the same history, in terms of free and bound periods up to a fixed time. In Subsection 8.1 we accomplish this, up to the first regular return. In Subsection 8.2 we realize that the same result may be achieved even if we consider the itineraries up to a some other return.

**8.1. Proximity after the first return.** Recall that the return time function  $R$  is constant on each  $s$ -sublattice and, in particular, on each  $\gamma^s$ . Thus, the return time function  $R$  needs only to be defined in  $\Lambda \cap W_1$  or in its vertical projection in the  $x$ -axis  $\Omega_\infty$ . Let  $(\Upsilon_{n,j})_j$  denote the family of subsets of  $\Omega_0$  for which  $\bar{\pi}^{-1}(H(\Upsilon_{n,j})) \cap \Lambda$  correspond to the  $s$ -sublattices of  $\Lambda$  given by [BY00, Proposition A] and such that  $R(H(\Upsilon_{n,j})) = n$ . Observe that  $\Upsilon_{n,j}$  determines univocally the corresponding  $s$ -sublattice and we allow some imprecision by referring ourselves to  $\Upsilon_{n,j}$  as an  $s$ -sublattice. The advantage of looking at the  $s$ -sublattices as projected subsets on the  $x$ -axis is that we can compare these projections of the  $s$ -sublattices of different dynamics since all of them live in the same interval,  $\Omega_0$ , of the  $x$ -axis. In Proposition 8.7 we obtain proximity of all the  $s$ -sublattices  $\Upsilon_{n,j}$ , with  $n \leq N$ , for a fixed integer  $N$  and sufficiently close Benedicks-Carleson parameters.

Let us give some insight into the argument. We consider  $(a, b) \in \mathcal{BC}$  and  $\Omega_\infty$  built according to Section 4. Let  $N \in \mathbb{N}$  be given. We make some modifications in the procedure described in Subsection 4.4.1 where the  $s$ -sublattices are defined so that for each  $\Upsilon_{n,j}$ , where  $n \leq N$ , we obtain an approximation  $\Upsilon_{n,j}^* \supset \Upsilon_{n,j}$  whose accuracy depends on the choice of a large integer  $N_3$ . Moreover, using Lemmas 6.3 and 7.2 we realize that, by construction,  $\Upsilon_{n,j}^*$  also suits as an approximation of  $\Upsilon'_{n,j} \subset \Upsilon_{n,j}^*$ , which is an  $s$ -sublattice corresponding to  $\Upsilon_{n,j}$  for a sufficiently close  $(a', b') \in \mathcal{BC}$ . The result follows once we verify that  $|\Upsilon_{n,j}^* - \Upsilon_{n,j}| \approx |\Upsilon_{n,j}^* - \Upsilon'_{n,j}|$ . Recall that, by construction, for each  $\Upsilon_{n,j}$  there are  $I \in \tilde{\mathcal{P}}_{n-1}$ ,  $\omega = H(I)$  and  $n$  a regular return time for  $\omega$  such that

$$\Upsilon_{n,j} = H^{-1}(f^{-n}(H(\Omega_\infty)) \cap \omega \cap \Lambda) = H^{-1}(f^{-n}(H(\Omega_\infty)) \cap \omega).$$

Observe that since  $f^n(\omega) \geq 3|\Omega_0|$  then  $\omega$  has a minimum length  $|\omega| \geq 5^{-n}3|\Omega_0|$ . This means that for  $n$  fixed there can only be a finite number of  $\Upsilon_{n,j}$ 's. In fact, if  $v(n)$  denotes the number of  $\Upsilon_{n,j}$  with  $R(H(\Upsilon_{n,j})) = n$ , then

$$v(n) \leq \frac{|\Omega_0|}{5^{-n}3|\Omega_0|} \leq 5^n. \quad (8.1)$$

Let  $N \in \mathbb{N}$  be given and let  $N_3 > 2N$  be a large integer whose choice will be specified later. Let  $\varepsilon < b^{2N_3}$  be small. Consider  $\mathcal{U}$  small enough so that condition (6.2) holds for such an  $\varepsilon$  and  $\Omega_j = \Omega'_j$  for all  $j \in \{0, \dots, N_3\}$  (recall Lemma 6.3), while  $\Omega'_\infty$  is built in usual way out of  $\Omega'_{N_3}$ .

For  $n \leq N$  we carry out an inductive construction of sets  $\tilde{\Omega}_n^* \subset \Omega_n$  and partitions  $\tilde{\mathcal{P}}_n^*$  of  $\tilde{\Omega}_n^*$  that will coincide for all  $(a', b') \in \mathcal{U}$ , for every  $n \leq N$ . This process must ensure that for every  $n \leq N$  we have  $\tilde{\Omega}_n^* \subset \tilde{\Omega}_n$ , and if  $\omega^* \in H(\tilde{\mathcal{P}}_n^*)$ , then there is  $\omega \in H(\tilde{\mathcal{P}}_n)$  such that  $\omega \supset \omega^*$ . Moreover, by choice of  $N_3$  we will have that  $\omega \setminus \omega^*$ , when not empty, occupies the tips of  $\omega$  and it corresponds to such a small part that if  $\omega$  has a regular return at time  $n < j \leq N$  then  $f^j(\omega^*) \supset 2\Omega_0$  still traverses  $Q_0$  by wide margins (see Lemma 8.1).

**8.1.1. Rules for defining  $\tilde{\Omega}_n^*$ ,  $\tilde{\mathcal{P}}_n^*$  and  $R^*$ .**

$$(0^*) \quad \tilde{\Omega}_0^* = \tilde{\Omega}'_0 = \Omega_0, \quad \tilde{\mathcal{P}}_0^* = \tilde{\mathcal{P}}'_0 = \{\Omega_0^*\}.$$

Assume that  $\tilde{\Omega}_{n-1}^* = \tilde{\Omega}'_{n-1}$  and that for each  $I^* \in \tilde{\mathcal{P}}_{n-1}^*$  there is  $I \in \tilde{\mathcal{P}}_{n-1}$  such that  $I \supset I^*$ . Take  $I^* \in \tilde{\mathcal{P}}_{n-1}^* = \tilde{\mathcal{P}}'_{n-1}$ . We denote  $\omega = H(I)$ ,  $\omega^* = H(I^*)$  and  $\omega^{*'} = H'(I^*)$ .

(1\*) If  $\omega \in \tilde{\mathcal{P}}_{n-1}$  does not make a regular return to  $H(\Omega_0)$  at time  $n$ , put  $\tilde{I}^* = I^* \cap \Omega_n$  into  $\tilde{\Omega}_n^*$  and let  $\tilde{\mathcal{P}}_n^*|_{\tilde{I}^*} = H^{-1} \left( f_{a,b}^{-n} \mathcal{P} \Big|_{H(\tilde{I}^*)} \right)$  with the usual adjoining of intervals.

We remark that if we were to apply this rule directly to  $(a', b') \in \mathcal{U} \cap \mathcal{BC}$ , where  $\mathcal{U}$  is sufficiently small so that Proposition 5.3, Lemma 6.3 and equation (6.2) hold for such  $\varepsilon$  and  $N_3$ , then  $\tilde{\Omega}_n^*$  and  $\tilde{\mathcal{P}}_n^*$  would have discrepancies of  $\mathcal{O}(\varepsilon)$  relative to  $\tilde{\Omega}_n^*$  and  $\tilde{\mathcal{P}}_n^*$  built for  $(a, b)$ , respectively. But  $\varepsilon < e^{-2N_3}$  is negligible when compared to  $e^{-\alpha N}$  or  $e^{-\alpha N}/N^2$ . Observe that the points of  $H(\tilde{I}^*)$  never get any closer than  $e^{-\alpha N}$  from the critical set, up to time  $n$ , and  $e^{-\alpha N}/N^2$  is the minimum size of the elements of the partition  $\mathcal{P}$  whose distance to the critical set is larger than  $e^{-\alpha N}$ . Hence, there is no harm in setting  $\tilde{\Omega}_n^{I^*} = \tilde{\Omega}_n^*$  and  $\tilde{\mathcal{P}}_n^{I^*} = \tilde{\mathcal{P}}_n^*$ .

Let  $\mathcal{S}_{N_3}$  be the partition of  $\Omega_{N_3}$  into connected components. We clearly have  $\#\mathcal{S}_{N_3} \leq 2^{N_3}$ . We write  $f^n(z) \in H(\Omega_{N_3})$  if there exists  $\sigma \in \mathcal{S}_{N_3}$  such that  $f^n(z) \in Q_{N_3-1}^2(H(\sigma))$  where, as before,  $Q_{N_3-1}^2(H(\sigma))$  is a  $2(Cb)^{N_3}$ -neighborhood of  $Q_{N_3-1}(H(\sigma))$  in  $\mathbb{R}^2$ . This way let  $f^{-n}(H(\Omega_{N_3}))$  have its obvious meaning. Observe that by definition of  $Q_{N_3-1}^2(H(\sigma))$  and the construction of the long stable curves (namely (4.1)), then

$$f^{-n}(H(\Omega_{N_3})) \supset f^{-n}(H(\Omega_\infty)), \quad (8.2)$$

where we write  $f^n(z) \in H(\Omega_\infty)$  when  $f^n(z) \in \gamma^s(\zeta)$  for some  $\zeta \in H(\Omega_\infty)$ .

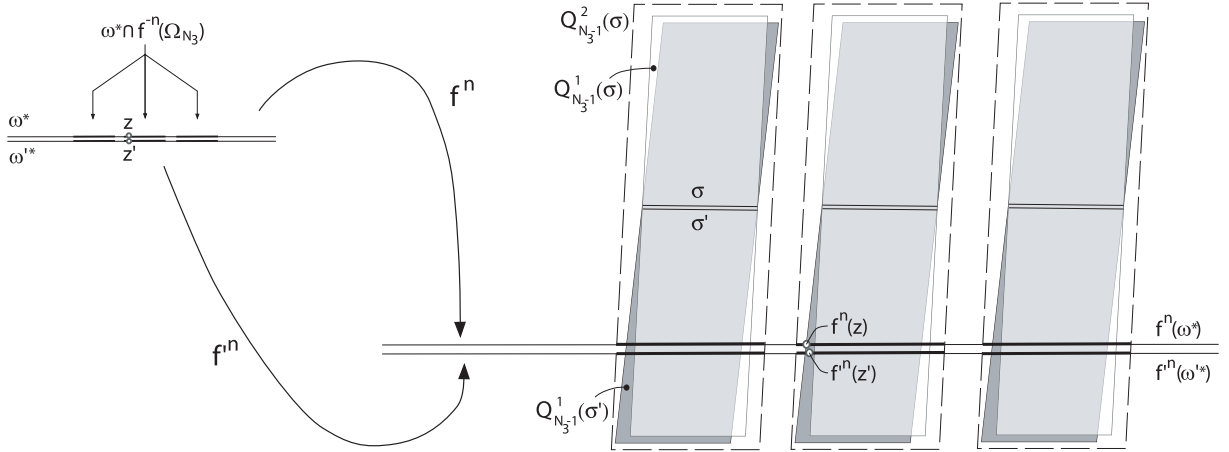

FIGURE 6

(2\*) If  $\omega \in \tilde{\mathcal{P}}_{n-1}$  makes a regular return at time  $n$ , we put

$$\tilde{I}^* = H^{-1} \left( \omega^* \setminus f^{-n}(H(\Omega_{N_3})) \right) \cap \Omega_n$$



into  $\tilde{\Omega}_n^*$ . Let  $\mathcal{S}^*$  be the partition of  $\tilde{I}^*$  into connected components. We define  $\tilde{\mathcal{P}}_n^*|_{\tilde{I}^*} = H^{-1}\left(f^{-n}\mathcal{P}|_{H(\tilde{I}^*)}\right) \vee \mathcal{S}^*$ . For  $z \in \omega^*$  such that  $f^n(z) \in H(\Omega_{N_3})$  we define  $R^*(z) = n$ .

Suppose that  $\mathcal{U}$  is sufficiently small so that as in Lemma 7.2 we have  $Q_{N_3-1}^2(H(\sigma)) \supset Q_{N_3-1}^1(H'(\sigma))$  and, as before, Proposition 5.3 and condition (6.2) hold for the considered  $\varepsilon$  and  $N_3$ . Then, the smallness of  $\varepsilon < b^{2N_3}$  when compared to the sizes of the elements  $f^n(H(\tilde{\mathcal{P}}_n^*))$  for  $n \leq N$  allows us to consider  $\tilde{\Omega}_n^* = \tilde{\Omega}'_n$  and  $\tilde{\mathcal{P}}_n^* = \tilde{\mathcal{P}}'_n$ .

Essentially in this construction we substitute  $\Omega_\infty$  by its finite approximation  $\Omega_{N_3}$  in order to relate the partitions built for  $(a, b)$  with the ones built for  $(a', b') \in \mathcal{U} \cap \mathcal{BC}$ . The sets  $\{R = n\} = \tilde{\Omega}_{n-1} \setminus \tilde{\Omega}_n$  were defined as the sets of points that at time  $n$  had their first regular return to  $H(\Omega_\infty)$  (after sliding along  $\gamma^s$  stable curves). Now  $\{R^* = n\} = \tilde{\Omega}_{n-1}^* \setminus \tilde{\Omega}_n^*$  is defined as the set of points that at time  $n$  have their first regular return to  $H(\Omega_{N_3})$ , where the sliding is made along the stable curve approximates,  $\gamma_{N_3}$ .

Let us make clear some aspects related to the previous rules. When we apply rule (2\*) at step  $n$ , we ensure that for every  $z \in \tilde{\Omega}_n^*$  we have  $z \notin f^{-n}(H(\Omega_\infty))$ . Let us verify that the same applies to  $f_{a',b'}$ , ie, since we are considering  $\mathcal{U}$  sufficiently small so that Lemma 7.2, Proposition 5.3 and condition (6.2) hold for  $\varepsilon$  and  $N_3$  in question, then for every  $z' \in \tilde{\Omega}'_n$  we have  $z' \notin f_{a',b'}^{-n}(H'(\Omega'_\infty))$ . Since  $\varepsilon$  is irrelevant when compared to  $2(Cb)^{N_3}$  we have for all  $z' \in H'(\tilde{\Omega}'_n)$  and for every  $\sigma \in \mathcal{S}_{N_3}$ ,  $\text{dist}(f_{a',b'}^n(z'), Q_{N_3-1}(H(\sigma))) > 2(Cb)^{N_3} - \varepsilon$  which implies that  $\text{dist}(f_{a',b'}^n(z'), Q_{N_3-1}(H'(\sigma))) > (Cb)^{N_3}$ , since by Lemma 7.2 we may assume that  $Q_{N_3-1}^1(H'(\sigma)) \subset Q_{N_3-1}^2(H(\sigma))$  and  $\text{dist}(Q_{N_3-1}(H'(\sigma)), Q_{N_3-1}(H(\sigma))) \leq \varepsilon$ . We have used “dist” to denote the usual distance between two sets.

In next lemma take into account that since  $\Omega_{N_3} \supset \Omega_\infty$ , then the gaps of  $\Omega_\infty$  contain those of  $\Omega_{N_3}$ , and so for all  $n \leq N$  and  $\omega^* \in H(\tilde{\mathcal{P}}_{n-1}^*)$  there exists  $\omega \in H(\tilde{\mathcal{P}}_{n-1})$  such that  $\omega^* \subset \omega$ .

**Lemma 8.1.** *Let  $n \leq N$ ,  $\omega^* \in H(\tilde{\mathcal{P}}_{n-1}^*)$  and consider  $\omega \in H(\tilde{\mathcal{P}}_{n-1})$  such that  $\omega^* \subset \omega$ . If  $N_3$  is large enough then  $f^n(\omega) \setminus f^n(\omega^*)$ , when not empty, occupies one or both tips of  $f^n(\omega)$  and  $|f^n(\omega) \setminus f^n(\omega^*)| < |\Omega_0|^2$ .*

*Proof.* Let  $N_3 \in \mathbb{N}$  be sufficiently large so that

$$5^N \left( C_1 \delta^{1-3\beta} \frac{e^{-\alpha(1-3\beta)(N_3+1)}}{1 - e^{-\alpha(1-3\beta)}} + 2(Cb)^{N_3} \right) < |\Omega_0|^2. \quad (8.3)$$

For every  $i \leq n-1$ , let  $\omega_i^* \in H(\tilde{\mathcal{P}}_i^*)$  be such that  $\omega^* \subset \omega_i^*$  and let  $\omega_i \in H(\tilde{\mathcal{P}}_i)$  be such that  $\omega \subset \omega_i$ . If  $\omega \setminus \omega^* \neq \emptyset$  then at some time before  $n-1$ , rule (2\*) was applied. Let  $j \leq n-1$  be the last moment in the history of  $\omega^*$  that rule 2\* was applied. Then,  $f^j(\omega_j^*)$  hits a gap of  $\Omega_{N_3}$  while  $f^j(\omega_j)$  hits a gap of  $\Omega_\infty$ . According to Lemma 6.1 the difference  $f^j(\omega_j) \setminus f^j(\omega_j^*)$  has length of at most

$$C_1 \delta^{1-3\beta} \frac{e^{-\alpha(1-3\beta)(N_3+1)}}{1 - e^{-\alpha(1-3\beta)}} + 2(Cb)^{N_3},$$

where the last term results from the fact that we are using  $2(Cb)^{N_3}$ -neighborhoods of the rectangles spanned by the approximate stable curves. Moreover,  $f^j(\omega_j) \setminus f^j(\omega_j^*)$  clearly occupies the tips of  $f^j(\omega_j)$ .

Now, for simplicity suppose that  $\omega = \omega_j$  and  $\omega^* = \omega_j^*$ . We have that  $f^n(\omega) \setminus f^n(\omega^*)$  occupies the tips of  $f^n(\omega)$ . This geometric property is inherited since by construction we are away from the folds and  $f$  is a diffeomorphism. Also, up to time  $n$ ,  $|f^j(\omega_j) \setminus f^j(\omega_j^*)|$  can grow no more than  $5^{n-j}$ . Consequently, by choice of  $N_3$  we must have  $|f^n(\omega) \setminus f^n(\omega^*)| < |\Omega_0|^2$ .

In the case that  $\omega \neq \omega_j$  it means that  $\omega_j$  will suffer exclusions or subdivisions. Nevertheless, the points of  $(\omega_j - \omega_j^*) \cap \omega$  still occupy the tip of  $f^n(\omega)$ .  $\square$

*Remark 8.2.* Observe that by choice of  $N_3$  we have that if  $\omega^* \in H(\tilde{\mathcal{P}}_{n-1}^*)$  and  $f^n(\omega)$  makes a regular return then  $f^n(\omega^*) \supset (3 - |\Omega_0|^2)\Omega_0$ . This means that for  $\mathcal{U}$  sufficiently small  $f_{a',b'}^n(\omega^*) \supset (3 - |\Omega_0|^2 - \varepsilon)\Omega_0$ .

When at step  $n$  we have to apply rule (2\*) we make more exclusions from  $\tilde{\Omega}_{n-1}^*$  than we would if we were to apply rule (2) as in [BY00]. Essentially we are excluding the points that hit  $H(\Omega_{N_3})$  instead of only removing the points that hit  $H(\Omega_\infty)$  ( $\Omega_\infty \subset \Omega_{N_3}$ ). We argue that by adequate choice of  $N_3$  this over exclusion will not affect the sets  $\{R^* = j\}$  with  $j \in \{n+1, \dots, N\}$ .

**Lemma 8.3.** *Suppose that  $x$  is a point that at step  $n$  should be excluded by rule (2\*) but is not excluded according to rule (2). If  $N_3$  is large enough, then  $H(x)$  does not have a regular return to  $\Omega_0$  before  $N$ .*

*Proof.* Let  $N_3 \in \mathbb{N}$  be sufficiently large so that (8.3) holds and take  $\sigma \in \mathcal{S}_{N_3}$ . When we apply rule (2\*) at step  $n$  we remove from  $\tilde{\Omega}_{n-1}^*$  all the points hitting  $H(\sigma)$ , while if we had applied rule (2) instead we would have only removed the points hitting  $H(\sigma \cap \Omega_\infty)$ . Consider a gap  $\varpi$  of  $H(\sigma \cap \Omega_\infty)$ . We know that the length of  $\varpi$  is less than

$$C_1 \delta^{1-3\beta} \frac{e^{-\alpha(1-3\beta)N_3}}{1 - e^{-\alpha(1-3\beta)}}.$$

If  $\partial\varpi \cap \partial H(\sigma) = \emptyset$  then  $\varpi \in \tilde{\mathcal{P}}_n$  and in  $N$  iterations it would grow to reach at most the length

$$5^N C_1 \delta^{1-3\beta} \frac{e^{-\alpha(1-3\beta)N_3}}{1 - e^{-\alpha(1-3\beta)}} < |\Omega_0|^2 \ll 3|\Omega_0|.$$

Thus,  $\varpi$  would not have any regular return to  $\Omega_0$  before  $N$ .

If  $\partial\varpi \cap \partial H(\sigma) \neq \emptyset$ , then there is a gap  $\hat{\varpi}$  of  $H(\Omega_\infty)$  so that  $\hat{\varpi} \in \tilde{\mathcal{P}}_n$  and  $\varpi$  occupies a tip of  $\hat{\varpi}$ . Clearly,  $\hat{\varpi}$  could have a regular return at  $j \in \{n+1, \dots, N\}$ , say. However, by construction  $f^j(\varpi)$  will occupy one tip of  $f^j(\hat{\varpi})$ . Since

$$|f^j(\varpi)| < 5^N C_1 \delta^{1-3\beta} \frac{e^{-\alpha(1-3\beta)N_3}}{1 - e^{-\alpha(1-3\beta)}} < |\Omega_0|^2$$

and  $|f^j(\hat{\varpi})| \gtrsim 3|\Omega_0|$  we still have that  $f^j(\varpi)$  does not hit  $\Omega_0$ . We remark that  $\hat{\varpi}$  could have suffered subdivisions and exclusions according to rule (1\*) before time  $j$ . Nevertheless, the

points from  $\varpi$  that survive the exclusions still occupy the tip of the piece that will contain them at the time of its regular return and the argument applies again.  $\square$

By the rules in Subsection 4.4.1, for every  $s$ -sublattice  $\Upsilon_{n,j}$  there is a segment  $\omega_{n,j} \in H(\tilde{\mathcal{P}}_{n-1})$  such that  $n$  is a regular return time for  $\omega_{n,j}$  and

$$\Upsilon_{n,j} = H^{-1}(\omega_{n,j} \cap f^{-n}(\Omega_\infty)). \quad (8.4)$$

Lemmas 8.1 and 8.3 allow us to conclude that if  $\omega_{n,j} \in \tilde{\mathcal{P}}_{n-1}$  and  $n \leq N$  is a regular return time for  $\omega_{n,j}$  then there is  $\omega_{n,j}^* \in \tilde{\mathcal{P}}_{n-1}^*$  such that  $\omega_{n,j}^* \subset \omega_{n,j}$  and  $|f^n(\omega_{n,j})| = |f^n(\omega_{n,j}^*)| + \mathcal{O}(|\Omega_0|^2)$ . Moreover, because the difference between  $\omega_{n,j}$  and  $\omega_{n,j}^*$  is only in their tips we may write

$$\Upsilon_{n,j} = H^{-1}(\omega_{n,j}^* \cap f^{-n}(\Omega_\infty)). \quad (8.5)$$

Attending to the procedure above and equation (8.5), given an  $s$ -sublattice  $\Upsilon_{n,j}$ , with  $n \leq N$  we define its approximation

$$\Upsilon_{n,j}^* = H^{-1}(\omega_{n,j}^* \cap f^{-n}(\Omega_{N_3})). \quad (8.6)$$

Taking into consideration (8.2) we have that  $\Upsilon_{n,j} \subset \Upsilon_{n,j}^*$ , from where we conclude that  $\forall n \in \{1, \dots, N\}$ ,

$$\{R = n\} = \bigcup_{j \leq v(n)} \Upsilon_{n,j} \subset \bigcup_{j \leq v(n)} \Upsilon_{n,j}^* = \{R^* = n\}.$$

We wish to verify that this substitution of  $\Omega_\infty$  by  $\Omega_{N_3}$  does not produce significant changes. In fact, we will show in the next lemma that  $\Upsilon_{n,j}$  and  $\Upsilon_{n,j}^*$  are very close for all  $n \leq N$  and  $j \leq v(n)$ .

**Lemma 8.4.** *Let  $\varepsilon > 0$ ,  $N \in \mathbb{N}$  and an  $s$ -sublattice  $\Upsilon_{n,j}$  with  $n \leq N$  be given. If  $N_3$  is large enough, then*

$$|\Upsilon_{n,j}^* \setminus \Upsilon_{n,j}| < \varepsilon \quad \text{and} \quad |\{R^* = n\} \setminus \{R = n\}| < \varepsilon.$$

*Proof.* Choose  $N_3$  large enough so that

$$C_1 |\Omega_{N_3} \setminus \Omega_\infty| < \varepsilon. \quad (8.7)$$

Let  $\omega_{n,j}^*$  be such that  $H(\Upsilon_{n,j}) = \omega_{n,j} \cap f^{-n}(H(\Omega_\infty))$  and  $H(\Upsilon_{n,j}^*) = \omega_{n,j}^* \cap f^{-n}(H(\Omega_{N_3}))$ . By bounded distortion we have

$$\frac{|H(\Upsilon_{n,j}^*) \setminus H(\Upsilon_{n,j})|}{|\omega_{n,j}^*|} \leq C_1 \frac{|f^n(H(\Upsilon_{n,j}^*) \setminus H(\Upsilon_{n,j}))|}{|f^n(\omega_{n,j}^*)|} \leq C_1 \frac{|\Omega_{N_3} \setminus \Omega_\infty|}{2|\Omega_0|}.$$

Attending to (8.7) this gives that  $|\Upsilon_{n,j}^* \setminus \Upsilon_{n,j}| < \varepsilon$ . Besides,

$$\begin{aligned} |\{R^* = n\} \setminus \{R = n\}| &= \sum_{j \leq v(n)} |\Upsilon_{n,j}^* \setminus \Upsilon_{n,j}| \leq \sum_{j \leq v(n)} C_1 \frac{|\Omega_{N_3} \setminus \Omega_\infty|}{|\Omega_0|} |\omega_{n,j}^*| \\ &\leq C_1 |\Omega_{N_3} \setminus \Omega_\infty| \\ &< \varepsilon, \end{aligned}$$

by the choice of  $N_3$ .  $\square$

*Remark 8.5.* By definition of  $f^{-n}(H(\Omega_{N_3}))$ , in the estimates above we should have considered  $|\Omega_{N_3}^2 \setminus \Omega_\infty|$ , where  $\Omega_{N_3}^2$  is a  $2(Cb)^{N_3}$ -neighborhood of  $\Omega_{N_3}$ . However, since  $\Omega_{N_3}$  has at most  $2^{N_3}$  connected components, then the difference to the estimates above would be at most  $2^{N_3+1}(Cb)^{N_3}$ , which is as small as we want if we choose  $N_3$  large enough.

*Remark 8.6.* The estimates in the proof were used taking  $H(\Omega_{N_3})$  and  $H(\Omega_\infty)$  as subsets of  $W_1$ . According to [BY00, Remark 5], upon re-scaling the estimates still work if we consider them as subsets of  $\gamma^u \in \Gamma^u$ , due to Lemma 2 of [BY00].

**Proposition 8.7.** *Let  $(a, b) \in \mathcal{BC}$ ,  $N \in \mathbb{N}$  and  $\varepsilon > 0$  be given. There is a neighborhood  $\mathcal{U}$  of  $(a, b)$  such that for all  $(a', b') \in \mathcal{U} \cap \mathcal{BC}$  given any  $s$ -sublattice  $\Upsilon_{n,j} \subset \Omega_\infty$ , with  $n \leq N$  and  $j \leq v(n)$ , then the corresponding  $s$ -sublattice  $\Upsilon'_{n,j} \subset \Omega'_\infty$  is such that*

$$|\Upsilon_{n,j} \triangle \Upsilon'_{n,j}| < \varepsilon \quad \text{and} \quad |\{R = n\} \triangle \{R' = n\}| < \varepsilon.$$

*Proof.* By Lemma 6.3 we are assuming that  $\Omega'_\infty$  is built out of  $\Omega_{N_3}$  in the usual way for  $f_{a',b'}$  with  $(a', b') \in \mathcal{U} \cap \mathcal{BC}$ . Lemma 7.2 assures that if  $\mathcal{U}$  is small enough then  $Q_{N_3-1}^2(H(\sigma))$ , which is a  $2(Cb)^{N_3}$ -neighborhood of  $Q_{N_3-1}(H(\sigma))$ , contains  $Q_{N_3-1}^1(H'(\sigma))$  for every  $\sigma \in \mathcal{S}_{N_3}$ . Moreover, for any  $x \in \sigma$

$$\|\gamma_{N_3}(H(x)) - \gamma'_{N_3}(H'(x))\|_0 < b^{N_2+1}.$$

Let  $N_3$  be chosen according to equations (8.3) and (8.7) so that Lemmas 8.1 and 8.4 hold. Let  $\Upsilon_{n,j}$ , with  $n \leq N$ , be a given  $s$ -sublattice of  $H(\Omega_\infty)$ . Let  $I_{n,j}^* \in \tilde{\mathcal{P}}_{n-1}^*$  be such that

$$\Upsilon_{n,j} = H^{-1}(\omega_{n,j}^* \cap f^{-n}(H(\Omega_\infty))),$$

where  $\omega_{n,j}^* = H(I_{n,j}^*)$ . Suppose that  $\mathcal{U}$  is sufficiently small so that the construction of the partition is carried out simultaneously for the dynamics  $f_{a',b'}$  correspondent to any  $(a', b') \in \mathcal{U} \cap \mathcal{BC}$  and so that  $\tilde{\mathcal{P}}_m = \tilde{\mathcal{P}}_m^*$ , for all  $m \leq N$ , as it has been described in the procedure above. Then,  $f_{a',b'}^n(\omega_{n,j}^*) = f_{a',b'}^n(H'(I_{n,j}^*))$  crosses  $Q_0$  by wide margins and we may define

$$\Upsilon'_{n,j} = H'^{-1}(\omega_{n,j}^* \cap f_{a',b'}^{-n}(H'(\Omega'_\infty))).$$

Consider the approximation  $\Upsilon_{n,j}^*$  built in (8.6) for  $\Upsilon_{n,j}$ . We have seen that  $\Upsilon_{n,j} \subset \Upsilon_{n,j}^*$  and using Lemma 8.4 we may suppose that  $|\Upsilon_{n,j}^* \setminus \Upsilon_{n,j}| < \varepsilon/2$ . Now, we shall see that  $\Upsilon_{n,j}^*$  is also a good approximation for  $\Upsilon'_{n,j}$  if  $\mathcal{U}$  is sufficiently small.

First, we verify that  $\Upsilon'_{n,j} \subset \Upsilon_{n,j}^*$ . Let  $x \in \Upsilon'_{n,j}$ ,  $z = H(x)$  and  $z' = H'(x)$ . We need to check that if  $f_{a',b'}^n(z') \in \Lambda'$ , then  $f^n(z) \in Q_{N_3-1}^2(H(\sigma))$  for some  $\sigma \in \mathcal{S}_{N_3}$ . We are supposing that  $\mathcal{U}$  is sufficiently small so that (6.2) holds for  $\varepsilon < b^{2N_3}$  up to  $N_3$ , which implies that  $|f^n(z) - f_{a',b'}^n(z')| < b^{2N_3}$ . Since  $\Lambda' \subset \bigcup_{\sigma \in \mathcal{S}_{N_3}} Q_{N_3-1}^1(H'(\sigma))$ , we have  $f_{a',b'}^n(z') \in Q_{N_3-1}^1(H'(\sigma))$  for some  $\sigma \in \mathcal{S}_{N_3}$ . Under the assumptions described in the procedure above (namely that  $Q_{N_3-1}^1(H'(\sigma)) \subset Q_{N_3-1}^2(H(\sigma))$ ) and attending to equation (7.2) we get that  $\text{dist}(f_{a',b'}^n(z'), Q_{N_3-1}(H(\sigma))) < 3/2(Cb)^{N_3}$ , and thus  $\text{dist}(f^n(z), Q_{N_3-1}(H(\sigma))) < 2(Cb)^{N_3}$ .

Additionally, since the upper bound used for  $|\Omega_{N_3} \setminus \Omega_\infty|$  also works for  $|\Omega_{N_3} \setminus \Omega'_\infty|$  and the width of  $Q_{N_3-1}^1(H'(\sigma))$  differs from the width of  $Q_{N_3-1}^2(H(\sigma))$  by  $\mathcal{O}((Cb)^{N_3})$  we observe that the argument used in Lemma 8.4 gives us that  $|\Upsilon_{n,j}^* \setminus \Upsilon'_{n,j}| < \varepsilon/2$ . Therefore

$$|\Upsilon_{n,j} \Delta \Upsilon'_{n,j}| \leq |\Upsilon_{n,j}^* \setminus \Upsilon_{n,j}| + |\Upsilon_{n,j}^* \setminus \Upsilon'_{n,j}| < \varepsilon,$$

which gives the first part of the conclusion.

Suppose now that Lemma 8.4 holds and  $|\{R^* = n\} \setminus \{R = n\}| < \varepsilon/2$ . Observing that  $\{R' = n\} = \cup_{j \leq v(n)} \Upsilon'_{n,j}$ , then arguing as in Lemma 8.4, we have  $|\{R^* = n\} \setminus \{R' = n\}| < \varepsilon/2$ , as long as  $\mathcal{U}$  is sufficiently small. Finally,

$$|\{R = n\} \Delta \{R' = n\}| \leq |\{R = n\} \Delta \{R^* = n\}| + |\{R^* = n\} \Delta \{R' = n\}| < \varepsilon.$$

□

**8.2. Proximity after  $k$  returns.** Given  $z \in H(\Omega_\infty)$  we define

$$R^1(z) = R(z) \quad \text{and} \quad R^{i+1}(z) = R\left(f^{R^1+\dots+R^i}(z)\right), \quad \text{for } i \geq 1.$$

Observe that  $R^1 \equiv n$  in  $\Upsilon_{n,j}$ . Since  $f^R(H(\Upsilon_{n,j}))$  hits each stable leaf of  $\Lambda$ , it makes sense to partition  $f^R(H(\Upsilon_{n,j}))$  using again the levels  $H(\Upsilon_{n,j})$ , and set

$$\Upsilon_{(n_1,j_1)(n_2,j_2)} = \Upsilon_{n_1,j_1} \cap H^{-1}\left(f^{-n_1}(H(\Upsilon_{n_2,j_2}))\right).$$

In general, given  $k \in \mathbb{N}$ , we consider

$$\Upsilon_{(n_1,j_1)\dots(n_k,j_k)} = \Upsilon_{n_1,j_1} \cap H^{-1}\left(f^{-n_1}(H(\Upsilon_{n_2,j_2}))\right) \cap \dots \cap H^{-1}\left(f^{-(n_1+\dots+n_{k-1})}(H(\Upsilon_{n_k,j_k}))\right).$$

Notice that for every  $z \in H(\Upsilon_{(n_1,j_1)\dots(n_k,j_k)})$  we have  $R^i(z) = n_i$  for  $1 \leq i \leq k$ .

The main result in this subsection (Proposition 8.9) states that if we fix a parameter  $(a, b) \in \mathcal{BC}$  and  $N \in \mathbb{N}$ , then there is a neighborhood  $\mathcal{U}$  of  $(a, b)$  in  $\mathbb{R}^2$  such that for any set  $\Upsilon_{(n_1,j_1)\dots(n_k,j_k)}$  considered, with  $n_1, \dots, n_k \leq N$ , it is possible to build a shadow set  $\Upsilon'_{(n_1,j_1)\dots(n_k,j_k)}$  close to the original one, for any  $(a', b') \in \mathcal{U} \cap \mathcal{BC}$ .

Recall that each  $H(\Upsilon_{n,j}) = \omega_{n,j} \cap f^{-n}(\Omega_\infty)$  may also be written as  $H(\Upsilon_{n,j}) = \omega_{n,j}^* \cap f^{-n}(H(\Omega_\infty))$ , where  $\omega_{n,j} \supset \omega_{n,j}^*$  and  $n$  is a regular return time for  $\omega_{n,j}$ . The next result claims that something similar holds for  $\Upsilon_{(n_1,j_1)\dots(n_k,j_k)}$ . We say that  $z \in f^{-\ell}(\omega_{n,j}^*)$  whenever  $f^\ell(z) \in Q_n^2(\omega_{n,j}^*)$ , while, as usual,  $z \in f^{-\ell}(H(\Omega_\infty))$  means that  $f^\ell \in \gamma^s(\zeta)$  for some  $\zeta \in H(\Omega_\infty)$ .

**Lemma 8.8.** *Taking  $n_0 = 0$  and  $n_1, \dots, n_k$  with  $n_i \leq N$ , we have*

$$H(\Upsilon_{(n_1,j_1)\dots(n_k,j_k)}) = \bigcap_{i=0}^{k-1} f^{-(n_0+\dots+n_i)}(\omega_{n_{i+1},j_{i+1}}^*) \cap f^{-(n_1+\dots+n_k)}(H(\Omega_\infty)). \quad (8.8)$$

*Proof.* We begin with the easier inclusion

$$H(\Upsilon_{(n_1,j_1)\dots(n_k,j_k)}) \subset \bigcap_{i=0}^{k-1} f^{-(n_0+\dots+n_i)}(\omega_{n_{i+1},j_{i+1}}^*) \cap f^{-(n_1+\dots+n_k)}(H(\Omega_\infty)).$$

Observe that  $Q(H(\Upsilon_{n_i, j_i})) \subset Q_{n_i}^2(\omega_{n_i, j_i}^*)$ , where  $Q(H(\Upsilon_{n_i, j_i}))$  is the rectangle spanned by  $\bar{\pi}^{-1}(H(\Upsilon_{n_i, j_i}))$ . If  $z \in f^{-(n_1+\dots+n_{k-1})}(H(\Upsilon_{n_k, j_k}))$ , then  $f^{n_1+\dots+n_{k-1}}(z) \in \gamma^s(\zeta)$  for some  $\zeta \in H(\Upsilon_{n_k, j_k})$ . By definition of  $\Upsilon_{n_k, j_k}$  we have  $f^{n_k}(\zeta) \in \gamma^s(\hat{\zeta})$  for some  $\hat{\zeta} \in H(\Omega_\infty)$ . Then, [BY00, Lemma 2(3)] gives that  $f^{n_1+\dots+n_k}(z) \in \gamma^s(\hat{\zeta})$ , which implies that  $z \in f^{-(n_1+\dots+n_k)}(H(\Omega_\infty))$ .

Let us consider now the other inclusion. Since  $H(\Upsilon_{n_i, j_i}) = \omega_{n_i, j_i}^* \cap f^{-n_i}(H(\Omega_\infty))$  we only need to verify that for every  $i \in \{0, \dots, k-1\}$

$$z \in \bigcap_{i=0}^{k-1} f^{-(n_0+\dots+n_i)}(\omega_{n_{i+1}, j_{i+1}}^*) \cap f^{-(n_1+\dots+n_k)}(H(\Omega_\infty)) \Rightarrow f^{n_1+\dots+n_i}(z) \in H(\Omega_\infty).$$

By [BY00, Lemma 3] we have

$$\left( \bigcup_{\zeta \in \Omega_\infty} \gamma^s(\zeta) \right) \cap f^{n_{i+1}} \left( Q_{n_{i+1}}^2(\omega_{n_{i+1}, j_{i+1}}^*) \right) \subset \bigcup_{\zeta \in \Omega_\infty} f^{n_{i+1}}(\gamma^s(\zeta)).$$

As  $f^{n_1+\dots+n_{i+1}}(z) \in \left( \bigcup_{\zeta \in \Omega_\infty} \gamma^s(\zeta) \right) \cap f^{n_{i+1}} \left( Q_{n_{i+1}}^2(\omega_{n_{i+1}, j_{i+1}}^*) \right)$ , then there exists  $\zeta \in H(\Omega_\infty)$  such that  $f^{n_1+\dots+n_{i+1}}(z) \in f^{n_{i+1}}(\gamma^s(\zeta))$ , which is equivalent to say that  $f^{n_1+\dots+n_i}(z) \in \gamma^s(\zeta)$ . This means that  $f^{n_1+\dots+n_i}(z) \in H(\Omega_\infty)$ .  $\square$

**Proposition 8.9.** *Let  $(a, b) \in \mathcal{BC}$ ,  $N \in \mathbb{N}$ ,  $k \in \mathbb{N}$  and  $\varepsilon > 0$  be given. There is an open neighborhood  $\mathcal{U}$  of  $(a, b)$  such that for each  $(a', b') \in \mathcal{U} \cap \mathcal{BC}$  and  $\Upsilon_{(n_1, j_1) \dots (n_k, j_k)}$  there is  $\Upsilon'_{(n_1, j_1) \dots (n_k, j_k)}$  such that in  $H'(\Upsilon'_{(n_1, j_1) \dots (n_k, j_k)})$  we have  $R'^1 = n_1, \dots, R'^k = n_k$  and*

$$|\Upsilon_{(n_1, j_1) \dots (n_k, j_k)} \triangle \Upsilon'_{(n_1, j_1) \dots (n_k, j_k)}| < \varepsilon.$$

*Proof.* The idea is to build for each  $\Upsilon_{(n_1, j_1) \dots (n_k, j_k)}$ , with  $n_1, \dots, n_k \leq N$ , an approximation  $\Upsilon_{(n_1, j_1) \dots (n_k, j_k)}^* \supset \Upsilon_{(n_1, j_1) \dots (n_k, j_k)}$  such that

$$|\Upsilon_{(n_1, j_1) \dots (n_k, j_k)}^* \setminus \Upsilon_{(n_1, j_1) \dots (n_k, j_k)}| < \frac{\varepsilon}{2}$$

and realize that  $\Upsilon_{(n_1, j_1) \dots (n_k, j_k)}^*$  also suits as an approximation for  $\Upsilon'_{(n_1, j_1) \dots (n_k, j_k)}$ , as long as  $\mathcal{U}$  is sufficiently small. We obtain an approximation of  $\Upsilon_{(n_1, j_1) \dots (n_k, j_k)}$  simply by substituting  $\Omega_\infty$  by  $\Omega_{N_4}$  in (8.8) for some large  $N_4$ . As before we say that  $f^n(z) \in H(\Omega_{N_4})$  whenever there is  $\sigma \in \mathcal{S}_{N_4}$  such that  $f^n(z) \in Q_{N_4-1}^2(H(\sigma))$ , which is a  $2(Cb)^{N_4}$ -neighborhood of  $Q_{N_4-1}(H(\sigma))$  in  $\mathbb{R}^2$ .

Define

$$\Upsilon_{(n_1, j_1) \dots (n_k, j_k)}^* = H^{-1} \left( \bigcap_{i=0}^{k-1} f^{-(n_0+\dots+n_i)}(\omega_{n_{i+1}, j_{i+1}}^*) \cap f^{-(n_1+\dots+n_k)}(H(\Omega_{N_4})) \right).$$

Since  $\Omega_\infty \subset \Omega_{N_4}$  we clearly have that  $\Upsilon_{(n_1, j_1) \dots (n_k, j_k)} \subset \Upsilon_{(n_1, j_1) \dots (n_k, j_k)}^*$ . Let us now obtain an estimate of  $|\Upsilon_{(n_1, j_1) \dots (n_k, j_k)}^* \setminus \Upsilon_{(n_1, j_1) \dots (n_k, j_k)}|$ . Considering

$$\omega = \bigcap_{i=0}^{k-1} f^{-(n_0 + \dots + n_i)}(\omega_{n_{i+1}, j_{i+1}}^*), \quad \omega^* = H(\Upsilon_{(n_1, j_1) \dots (n_k, j_k)}^*), \quad \tilde{\omega} = H(\Upsilon_{(n_1, j_1) \dots (n_k, j_k)})$$

we get

$$\frac{|\omega^* \setminus \tilde{\omega}|}{|\omega|} \leq C_1 \frac{|f^{n_1 + \dots + n_k}(\omega^*) \setminus f^{n_1 + \dots + n_k}(\tilde{\omega})|}{f^{n_1 + \dots + n_k}(\omega)} \leq \frac{C_1}{2|\Omega_0|} (|\Omega_{N_4} \setminus \Omega_\infty| + 4(Cb)^{N_4})$$

Thus, if  $N_4$  is sufficiently large we have

$$|\Upsilon_{(n_1, j_1) \dots (n_k, j_k)}^* \setminus \Upsilon_{(n_1, j_1) \dots (n_k, j_k)}| < \frac{\varepsilon}{2}. \quad (8.9)$$

Suppose now that we take a sufficiently small neighborhood  $\mathcal{U}$  of  $(a, b)$  so that if  $(a', b') \in \mathcal{U} \cap \mathcal{BC}$ , then the following conditions hold:

- (1)  $\Omega'_\infty$  is built out of  $\Omega'_{N_4} = \Omega_{N_4}$  in the usual way, as in Lemma 6.3;
- (2)  $Q_{N_4-1}^2(H(\sigma)) \supset Q_{N_4-1}^1(H'(\sigma))$  for each  $\sigma \in \mathcal{S}_{N_4}$  and, as in Lemma 7.2,

$$\text{dist}(Q_{N_4-1}(H(\sigma)), Q_{N_4-1}(H'(\sigma))) < b^{N_4+1};$$

- (3) the procedure in Subsection 8.1 leads to  $\tilde{\Omega}_n^* = \tilde{\Omega}'_n$  and  $\tilde{\mathcal{P}}_n^* = \tilde{\mathcal{P}}'_n$ , for all  $n \leq N$ ;
- (4) equation (6.2) holds for  $b^{2N_4}$  up to  $kN$ .

Within  $\mathcal{U}$  it makes sense to define

$$\Upsilon'_{(n_1, j_1) \dots (n_k, j_k)} = H'^{-1} \left( \bigcap_{i=0}^{k-1} f_{a', b'}^{-(n_0 + \dots + n_i)}(\omega_{n_{i+1}, j_{i+1}}^*) \cap f_{a', b'}^{-(n_1 + \dots + n_k)}(H'(\Omega'_\infty)) \right).$$

Moreover, one realizes that  $\Upsilon_{(n_1, j_1) \dots (n_k, j_k)}^*$  is a good approximation of  $\Upsilon'_{(n_1, j_1) \dots (n_k, j_k)}$ . In fact, we have that  $\Upsilon'_{(n_1, j_1) \dots (n_k, j_k)} \subset \Upsilon_{(n_1, j_1) \dots (n_k, j_k)}^*$ . To see this, observe first that the discrepancies of order  $b^{2N_4}$  in the tips of the intervals  $H^{-1}(f^{-(n_1 + \dots + n_i)}(\omega_{n_{i+1}, j_{i+1}}) \cap H(\Omega_0))$  and  $H'^{-1}(f_{a', b'}^{-(n_1 + \dots + n_i)}(\omega_{n_{i+1}, j_{i+1}}) \cap H'(\Omega_0))$  are negligible since we are only interested in the points of the center of this intervals that hit  $\Omega_0$  at their last regular return. Finally, note that by conditions (1), (2) and (4) above, we must have  $x \in \Upsilon_{(n_1, j_1) \dots (n_k, j_k)}^*$  whenever  $x \in \Upsilon'_{(n_1, j_1) \dots (n_k, j_k)}$ . Otherwise, we would have an  $x \in \Upsilon'_{(n_1, j_1) \dots (n_k, j_k)}$  such that  $z' = f_{a', b'}^{n_1 + \dots + n_k}(H'(x)) \in Q_{N_4-1}^1(H'(\sigma))$  for some  $\sigma \in \mathcal{S}_{N_4}$  and  $z = f^{n_1 + \dots + n_k}(H(x)) \notin Q_{N_4-1}^2(H(\sigma))$ , for all  $\sigma \in \mathcal{S}_{N_4}$ . But  $z \notin Q_{N_4-1}^2(H(\sigma))$  implies that  $\text{dist}(z, Q_{N_4-1}(H(\sigma))) > 2(Cb)^{N_4}$ , from where one derives by (2) that

$$\text{dist}(z, Q_{N_4-1}(H'(\sigma))) > 2(Cb)^{N_4} - b^{N_4+1} > \frac{3}{2}(Cb)^{N_4}$$

and

$$\text{dist}(z, Q_{N_4-1}^1(H'(\sigma))) > \frac{1}{2}(Cb)^{N_4}.$$

However, by (4),  $\text{dist}(z, z') < b^{2N_4}$  yields  $\text{dist}(z, Q_{N_4-1}^1(H'(\sigma))) < b^{2N_4}$ .

The argument used above to obtain the estimate (8.9) also gives that, for  $N_4$  large enough and  $\mathcal{U}$  sufficiently small,  $|\Upsilon_{(n_1, j_1) \dots (n_k, j_k)}^* \setminus \Upsilon'_{(n_1, j_1) \dots (n_k, j_k)}| < \varepsilon/2$ , from where one easily deduces that

$$|\Upsilon_{(n_1, j_1) \dots (n_k, j_k)} \triangle \Upsilon'_{(n_1, j_1) \dots (n_k, j_k)}| < \varepsilon.$$

□

## 9. STATISTICAL STABILITY

Fix a parameter  $(a_0, b_0) \in \mathcal{BC}$  and a horseshoe  $\Lambda_0$  given by Proposition 4.1. Consider a sequence  $(a_n, b_n) \in \mathcal{BC}$  converging to  $(a_0, b_0)$ . For each  $n \geq 0$  set  $f_n = f_{a_n, b_n}$  and assign an adequate horseshoe  $\Lambda_n$  in the sense of Proposition 4.1. Let  $W_1^n$  denote the leaf of first generation of the unstable manifold through  $z_n^*$ , the unique fixed point of  $f_n$  in the first quadrant, and a parametrization  $H_n : \Omega_0 \rightarrow W_1^n$  of the segment of  $W_1^n$  that projects vertically onto  $\Omega_0$  as in Section 6. Setting  $\Omega_\infty^n = H_n^{-1}(\Lambda_n \cap H_n(\Omega_0))$  let  $R_n : \Lambda_n \rightarrow \mathbb{N}$  denote the return time function and  $F_n = f_n^{R_n} : \Lambda_n \rightarrow \Lambda_n$ . For every  $z \in \Lambda_n$  we denote by  $\gamma_n^s(z)$  the long stable curve through  $z$ .

According to Corollary 6.4 and Propositions 7.3 and 8.7, we assume that all these objects have been constructed in such a way that:

- (1)  $|\Omega_\infty^n \triangle \Omega_\infty^0| \rightarrow 0$  as  $n \rightarrow \infty$ ;
- (2)  $\gamma_n^s(H_n(x)) \rightarrow \gamma_0^s(H_0(x))$  as  $n \rightarrow \infty$  in the  $C^1$ -topology;
- (3) for  $N \in \mathbb{N}$  and  $1 \leq j \leq N$  we have  $|\{R_n = j\} \triangle \{R_0 = j\}| \rightarrow 0$  as  $n \rightarrow \infty$ .

As mentioned in Section 3.8, we know that for all  $n \in \mathbb{N}_0$  there is a unique SRB measure  $\nu_n$ . Our goal is to show that  $\nu_n \rightarrow \nu_0$  in the weak\* topology, i.e. for all continuous functions  $g : \mathbb{R}^2 \rightarrow \mathbb{R}$  the integrals  $\int g d\nu_n$  converge to  $\int g d\nu_0$ . We will show that given any continuous  $g : \mathbb{R}^2 \rightarrow \mathbb{R}$ , each subsequence of  $\int g d\nu_n$  admits a subsequence converging to  $\int g d\nu_0$ .

**9.1. A subsequence in the quotient horseshoe.** We begin by considering for each  $n \in \mathbb{N}_0$ , the quotient horseshoes  $\bar{\Lambda}_n$  obtained from  $\Lambda_n$  by collapsing stable curves, as in Section 4.5, and the quotient map  $\bar{F}_n = \overline{f_n^{R_n}} : \bar{\Lambda}_n \rightarrow \bar{\Lambda}_n$ . Every unstable leaf  $\gamma_n^u$  in the definition of  $\Lambda_n$  suits as a model for  $\bar{\Lambda}_n$ , through the identification of each point  $z \in \gamma_n^u \cap \Lambda_n$  with its equivalence class,  $\gamma_n^s(z) \in \bar{\Lambda}_n$ . We have seen in Section 4.5 that there exists a well defined reference measure in  $\bar{\Lambda}_n$ , denoted by  $\bar{m}_n$ . From here and henceforth, for each  $n \in \mathbb{N}_0$  we fix the unstable leaf  $H_n(\Omega_0)$  and take  $H_n(\Omega_0) \cap \Lambda_n = H_n(\Omega_\infty^n)$  as our model for  $\bar{\Lambda}_n$ . The measure whose density with respect to Lebesgue measure on  $H_n(\Omega_0)$  is  $\mathbf{1}_{H_n(\Omega_\infty^n)}$  will be our representative for the reference measure  $\bar{m}_n$ , where  $\mathbf{1}_{(\cdot)}$  is the indicator function. In fact we will allow some imprecision by identifying  $\bar{\Lambda}_n$  with  $H_n(\Omega_\infty^n)$  and  $\bar{m}_n$  with its representative on  $H_n(\Omega_0)$ .

As referred in Section 4.5, for each  $n \in \mathbb{N}_0$  there is an  $\bar{F}_n$ -invariant density  $\bar{\rho}_n$ , with respect to the reference measure  $\bar{m}_n$ . We may assume that each  $\bar{\rho}_n$  is defined in the interval  $\Omega_0$  and  $\bar{\rho}_n(x) = \mathbf{1}_{\Omega_\infty^n}(x) \bar{\rho}_n(H_n(x))$  for every  $x \in \Omega_0$ . This way we have the sequence  $(\bar{\rho}_n)_{n \in \mathbb{N}_0}$  defined on the same interval  $\Omega_0$ .

**Lemma 9.1.** *There is  $M > 0$  such that  $\|\bar{\rho}_n\|_\infty \leq M$  for all  $n \geq 0$ .*



*Proof.* We follow the proof of [Yo98, Lemma 2] and construct  $\bar{\rho}$  as the density with respect to  $\bar{m}$  of an accumulation point of  $\bar{\nu}^n = 1/n \sum_{i=0}^{n-1} \bar{F}_*^i(\bar{m})$ . Let  $\bar{\rho}^n$  denote the density of  $\bar{\nu}^n$  and  $\bar{\rho}^i$  the density of  $\bar{F}_*^i(\bar{m})$ . Also, let  $\bar{\rho}^i = \sum_j \bar{\rho}_j^i$ , where  $\bar{\rho}_j^i$  is the density of  $\bar{F}_*^i(\bar{m}|\sigma_j^i)$  and the  $\sigma_j^i$ 's range over all components of  $\bar{\Lambda}$  such that  $\bar{F}^i(\sigma_j^i) = \bar{\Lambda}$ .

Consider the normalized density  $\tilde{\rho}_j^i = \bar{\rho}_j^i/\bar{m}(\sigma_j^i)$ . Let  $J\bar{F}$  denote the Radon-Nikodym derivative  $\frac{d(\bar{F}_*^{-1}\bar{m})}{d\bar{m}}$ . Observing that  $\bar{m}(\sigma_j^i) = \bar{F}_*^i\bar{m}(\bar{F}^i(\sigma_j^i))$  we have for  $\bar{x}' \in \sigma_j^i$  such that  $\bar{x} = \bar{F}^i(\bar{x}')$  and for some  $\bar{y}' \in \sigma_j^i$

$$\tilde{\rho}_j^i(\bar{x}) \lesssim \frac{J\bar{F}^i(\bar{y}')}{J\bar{F}^i(\bar{x}')}(\bar{m}(\bar{\Lambda}))^{-1} = \prod_{k=1}^i \frac{J\bar{F}(\bar{F}^{k-1}(\bar{y}'))}{J\bar{F}(\bar{F}^{k-1}(\bar{x}'))}(\bar{m}(\bar{\Lambda}))^{-1} \leq M(\bar{m}(\bar{\Lambda}))^{-1}.$$

To obtain the inequality above we appeal to [Yo98, Lemma 1(3)] or [BY00, Lemma 6]. A careful look at [BY00, Lemma 6] allows us to conclude that  $M$  does not depend on the parameter in question. Now,  $\bar{\rho}_j^i \leq M(\bar{m}(\bar{\Lambda}))^{-1} \sum_j \bar{m}(\sigma_j^i) \leq M$  which implies that  $\bar{\rho}^n \leq M$ , from where we obtain that  $\bar{\rho} \leq M$ .  $\square$

The starting point in construction of the desired convergent subsequence is to apply the Banach-Alaoglu Theorem to the sequence  $\bar{\rho}_n$  to obtain a subsequence  $(\bar{\rho}_{n_i})_{i \in \mathbb{N}}$  convergent to  $\bar{\rho}_\infty \in L^\infty$  in the weak\* topology, i.e.

$$\int \phi \bar{\rho}_{n_i} dx \xrightarrow{i \rightarrow \infty} \int \phi \bar{\rho}_\infty dx, \quad \forall \phi \in L^1. \quad (9.1)$$

**9.2. Lifting to the original horseshoe.** At this point we adapt a technique used in [Bo75] for the construction of Gibbs states to lift an  $\bar{F}$ -invariant measure on the quotient space  $\bar{\Lambda}$  to an  $F$ -invariant measure on the initial horseshoe  $\Lambda$ .

Associated to the  $\bar{F}$ -invariant probability measure  $\bar{\nu}$ , we define a probability measure  $\tilde{\nu}$  on  $\Lambda$  as follows. For each bounded  $\phi : \Lambda \rightarrow \mathbb{R}$  consider its discretization  $\phi^* : \bar{\Lambda} \rightarrow \mathbb{R}$  defined by

$$\phi^*(x) = \inf\{\phi(z) : z \in \gamma^s(H(x))\}. \quad (9.2)$$

If  $\phi$  is continuous, as its domain is compact, we may define

$$\text{var}\phi(k) = \sup\{|\phi(z) - \phi(\zeta)| : |z - \zeta| \leq Cb_0^k\},$$

in which case  $\text{var}\phi(k) \rightarrow 0$  as  $k \rightarrow \infty$ .

**Lemma 9.2.** *Given any continuous  $\phi : \Lambda \rightarrow \mathbb{R}$ , for all  $k, l \in \mathbb{N}$  we have*

$$\left| \int (\phi \circ F^k)^* d\bar{\nu} - \int (\phi \circ F^{k+l})^* d\bar{\nu} \right| \leq \text{var}\phi(k).$$

*Proof.* Since  $\bar{\nu}$  is  $\bar{F}$ -invariant

$$\begin{aligned} \left| \int (\phi \circ F^k)^* d\bar{\nu} - \int (\phi \circ F^{k+l})^* d\bar{\nu} \right| &= \left| \int (\phi \circ F^k)^* \circ \bar{F}^l d\bar{\nu} - \int (\phi \circ F^{k+l})^* d\bar{\nu} \right| \\ &\leq \int |(\phi \circ F^k)^* \circ \bar{F}^l - (\phi \circ F^{k+l})^*| d\bar{\nu}. \end{aligned}$$

By definition of the discretization we have

$$(\phi \circ F^k)^* \circ \bar{F}^l(x) = \min \{ \phi(z) : z \in F^k(\gamma^s(H(\bar{F}^l(x)))) \}$$

and

$$(\phi \circ F^{k+l})^*(x) = \min \{ \phi(\zeta) : \zeta \in F^{k+l}(\gamma^s(H(x))) \}.$$

Observe that  $F^{k+l}(\gamma^s(H(x))) \subset F^k(\gamma^s(H(\bar{F}^l(x))))$  and by Proposition 4.1

$$\text{diam } F^k(\gamma^s(H(\bar{F}^l(x)))) \leq Cb_0^k.$$

Thus,  $|(\phi \circ F^k)^* \circ \bar{F}^l - (\phi \circ F^{k+l})^*| \leq \text{var}\phi(k)$ .  $\square$

By the Cauchy criterion the sequence  $(\int (\phi \circ F^k)^* d\bar{\nu})_{k \in \mathbb{N}}$  converges. Hence, Riesz Representation Theorem yields a probability measure  $\tilde{\nu}$  on  $\Lambda$

$$\int \phi d\tilde{\nu} := \lim_{k \rightarrow \infty} \int (\phi \circ F^k)^* d\bar{\nu} \quad (9.3)$$

for every continuous function  $\phi : \Lambda \rightarrow \mathbb{R}$ .

**Proposition 9.3.** *The probability measure  $\tilde{\nu}$  is  $F$ -invariant and has absolutely continuous conditional measures on  $\gamma^u$  leaves. Moreover, given any continuous  $\phi : \Lambda \rightarrow \mathbb{R}$  we have*

- (1)  $|\int \phi d\tilde{\nu} - \int (\phi \circ F^k)^* d\bar{\nu}| \leq \text{var}\phi(k)$ ;
- (2) *If  $\phi$  is constant in each  $\gamma^s$ , then  $\int \phi d\tilde{\nu} = \int \bar{\phi} d\bar{\nu}$ , where  $\bar{\phi} : \bar{\Lambda} \rightarrow \mathbb{R}$  is defined by  $\bar{\phi}(x) = \phi(H(x))$ .*
- (3) *If  $\phi$  is constant in each  $\gamma^s$  and  $\psi : \Lambda \rightarrow \mathbb{R}$  is continuous then*

$$\left| \int \psi \cdot \phi d\tilde{\nu} - \int (\psi \circ F^k)^* (\phi \circ F^k)^* d\bar{\nu} \right| \leq \|\phi\|_\infty \text{var}\psi(k).$$

- (4)  $\tilde{\nu}$  is ergodic.

*Proof.* Regarding the  $F$ -invariance property, note that for any continuous  $\phi : \Lambda \rightarrow \mathbb{R}$ ,

$$\int \phi \circ F d\tilde{\nu} = \lim_{k \rightarrow \infty} \int (\phi \circ F^{k+1})^* d\bar{\nu} = \int \phi d\tilde{\nu},$$

by Lemma 9.2. Item (1) is an immediate consequence of Lemma 9.2. Item (2) follows from

$$\int \phi d\tilde{\nu} = \lim_{k \rightarrow \infty} \int (\phi \circ F^k)^* d\bar{\nu} = \lim_{k \rightarrow \infty} \int \bar{\phi} \circ \bar{F}^k d\bar{\nu} = \int \bar{\phi} d\bar{\nu}.$$

For item (3) let  $k, l$  be positive integers; then

$$\int (\psi \cdot \phi \circ F^k)^* d\bar{\nu} = \int (\psi \circ F^k)^* (\phi \circ F^k)^* d\bar{\nu}$$

and

$$\begin{aligned} \left| \int (\psi \phi \circ F^{k+l})^* d\bar{\nu} - \int (\psi \phi \circ F^k)^* d\bar{\nu} \right| &= \left| \int (\psi \circ F^{k+l})^* \bar{\phi} \circ \bar{F}^{k+l} d\bar{\nu} - \int (\psi \circ F^k)^* \bar{\phi} \circ \bar{F}^k d\bar{\nu} \right| \\ &\leq \int |(\psi \circ F^{k+l})^* - (\psi \circ F^k)^* \circ \bar{F}^l| |\phi \circ \bar{F}^{k+l}| d\bar{\nu} \\ &\leq \|\phi\|_\infty \text{var}\psi(k); \end{aligned}$$

inequality (3) follows letting  $l$  go to  $\infty$ .

*Remark 9.4.* Since the continuous functions are a dense subset of  $L^1$ - functions, then properties (2) and (3) also hold, through Lebesgue Dominated Convergence Theorem, when  $\phi \in L^1$ . In particular, this gives that  $\bar{\pi}_* \tilde{\nu} = \bar{\nu}$ .

In order to prove item (4), let  $\tilde{\mathcal{E}}$  denote the set of points  $z \in \Lambda$  such that for every  $g \in L^1(\tilde{\nu})$  we have

$$\lim_{n \rightarrow \infty} \frac{1}{n} \sum_{i=0}^{n-1} g \circ f^i(z) = \int g d\tilde{\nu}. \quad (9.4)$$

We define similarly  $\bar{\mathcal{E}}$  with respect to  $\bar{\nu}$ , points in  $\bar{\Lambda}$  and  $g \in L^1(\bar{\nu})$ . Recall that ergodicity of  $\bar{\nu}$  and  $\tilde{\nu}$  is equivalent to  $\bar{\nu}(\bar{\mathcal{E}}) = 1$  and  $\tilde{\nu}(\tilde{\mathcal{E}}) = 1$ , respectively. Actually, it is enough to consider continuous functions in the previous definitions. We will show that  $\bar{\pi}^{-1}(\bar{\mathcal{E}}) \subset \tilde{\mathcal{E}}$ , which then by Remark 9.4 implies that  $\tilde{\nu}$  is ergodic. Let  $\bar{x} \in \bar{\mathcal{E}}$ ,  $z \in \bar{\pi}^{-1}(\bar{x})$  and consider a continuous function  $g : \Lambda \rightarrow \mathbb{R}$ . Then for every  $k \in \mathbb{N}$  we have

$$\begin{aligned} \left| \frac{1}{n} \sum_{i=0}^{n-1} g(F^i(z)) - \int g d\tilde{\nu} \right| &\leq \left| \frac{1}{n} \sum_{i=0}^{k-1} g(F^i(z)) \right| + \frac{1}{n} \sum_{i=0}^{n-1} |g(F^{k+i}(z)) - (g \circ F^k)^*(F^i(\bar{x}))| \\ &+ \frac{1}{n} \left| \sum_{i=n-1}^{n+k-1} g(F^i(z)) \right| + \left| \frac{1}{n} \sum_{i=0}^{n-1} (g \circ F^k)^*(F^i(\bar{x})) - \int (g \circ F^k)^* d\bar{\nu} \right| + \left| \int (g \circ F^k)^* d\bar{\nu} - \int g d\tilde{\nu} \right| \\ &\leq \frac{2k\|g\|_\infty}{n} + 2\text{var}g(k) + \left| \frac{1}{n} \sum_{i=0}^{n-1} (g \circ F^k)^*(F^i(\bar{x})) - \int (g \circ F^k)^* d\bar{\nu} \right| \xrightarrow{n \rightarrow \infty} 2\text{var}g(k), \end{aligned}$$

and the conclusion follows by letting  $k \rightarrow \infty$ .

We are then left to verify the absolute continuity of  $\tilde{\nu}$ . We already know that  $\Lambda$  supports an  $F$ -invariant ergodic measure  $\nu$  with absolutely continuous conditional measures on  $\gamma^u$  leaves; see e.g. [Yo98, Section 2]. In fact, we know that on a.e.  $\gamma^u$ , the conditional measure  $\nu_{\gamma^u}$  is equivalent to the conditional 1-dimensional Lebesgue measure  $\lambda_{\gamma^u}$ , when restricted to  $\Lambda$ . We are going to show that  $\tilde{\nu} = \nu$ . Consider  $\mathcal{E}$  the set of points  $z \in \Lambda$  for which (9.4) holds with  $\nu$  instead of  $\tilde{\nu}$ . Our goal is to show that  $\mathcal{E} \cap \tilde{\mathcal{E}} \neq \emptyset$ , which gives the desired equality of the two measures. As  $\nu(\mathcal{E}) = 1$ , by the equivalence (on a.e.  $\gamma^u$ ) between  $\nu_{\gamma^u}$  and  $\lambda_{\gamma^u}$  restricted to  $\Lambda$ , there exists an unstable leaf  $\gamma^u$  such that  $\lambda_{\gamma^u}((\Lambda \setminus \mathcal{E}) \cap \gamma^u) = 0$ . By (4) we have  $\tilde{\nu}(\tilde{\mathcal{E}}) = 1$  which implies that  $\bar{\nu}(\bar{\pi}(\Lambda \setminus \tilde{\mathcal{E}})) = 0$  because  $\bar{\pi}_* \tilde{\nu} = \bar{\nu}$  by Remark 9.4. Since  $\bar{\nu}$  is equivalent to  $\bar{m}$ , it follows that  $\bar{m}(\bar{\pi}(\Lambda \setminus \tilde{\mathcal{E}})) = 0$ . Now, since the representative

of  $\bar{m}$  on  $\gamma^u$  is also equivalent to  $\lambda_{\gamma^u}$  restricted to  $\Lambda$ , we also have that  $\lambda_{\gamma^u}((\Lambda \setminus \tilde{\mathcal{E}}) \cap \gamma^u) = 0$ . Consequently, we have  $\lambda_{\gamma^u}((\mathcal{E} \cap \tilde{\mathcal{E}}) \cap \gamma^u) > 0$  which proves that  $\mathcal{E} \cap \tilde{\mathcal{E}} \neq \emptyset$ .  $\square$

Observe that while  $\bar{\nu}_{n_i}$  is  $\bar{F}_{n_i}$ -invariant we are not certain that  $\bar{\nu}_\infty = \bar{\rho}_\infty d\bar{m}_0$  is  $\bar{F}_0$ -invariant; thus we are not yet in condition to apply Lemma 9.2 to the measure  $\bar{\nu}_\infty$ . This invariance can be derived from the fact that  $\bar{\nu}_{n_i}$  is  $\bar{F}_{n_i}$ -invariant and equation (9.1).

**Lemma 9.5.** *The measure  $\bar{\nu}_\infty = \bar{\rho}_\infty d\bar{m}_0$  is  $\bar{F}_0$ -invariant.*

*Proof.* We just have to verify that for every continuous  $\varphi : \bar{\Lambda}_0 \rightarrow \mathbb{R}$

$$\int \varphi \circ \bar{F}_0 \cdot \bar{\rho}_\infty d\bar{m}_0 = \int \varphi \cdot \bar{\rho}_\infty d\bar{m}_0$$

Up to composing with  $H_0$  we can think of  $\varphi$  as a function defined in  $\Omega_\infty^0$ . Clearly, there is a continuous function  $\phi : \Omega_0 \rightarrow \mathbb{R}$  such that  $\phi|_{\Omega_\infty^0}(x) = \varphi(x)$ . Similarly, we can think of  $\phi$  as being defined in any set  $H_{n_i}(\Omega_0)$ . So, let us consider a continuous function  $\phi : \Omega_0 \rightarrow \mathbb{R}$ . Having this considerations in mind and the fact that  $\bar{\nu}_{n_i}$  is  $\bar{F}_{n_i}$ -invariant we have

$$\int \phi \circ \bar{F}_{n_i} \cdot \bar{\rho}_{n_i} d\bar{m}_{n_i} = \int \phi \cdot \bar{\rho}_{n_i} d\bar{m}_{n_i}. \quad (9.5)$$

Observing that

$$\int \phi \cdot \bar{\rho}_{n_i} d\bar{m}_{n_i} = \int \phi(x) \cdot \bar{\rho}_{n_i}(x) \cdot \left\| \frac{dH_{n_i}}{dx} \right\| dx$$

we conclude that

$$\int \phi(x) \cdot \bar{\rho}_{n_i}(x) \cdot \left\| \frac{dH_{n_i}}{dx} \right\| dx \xrightarrow{i \rightarrow \infty} \int \phi(x) \cdot \bar{\rho}_\infty(x) \cdot \left\| \frac{dH_0}{dx} \right\| dx \quad (9.6)$$

due to

$$\left| \int \phi \cdot \bar{\rho}_{n_i} \cdot \left\| \frac{dH_{n_i}}{dx} \right\| dx - \int \phi \cdot \bar{\rho}_\infty \cdot \left\| \frac{dH_0}{dx} \right\| dx \right| \leq \left| \int \phi \cdot \bar{\rho}_{n_i} \cdot \left\| \frac{dH_{n_i}}{dx} \right\| dx - \int \phi \cdot \bar{\rho}_{n_i} \cdot \left\| \frac{dH_0}{dx} \right\| dx \right| + \left| \int \phi \cdot \bar{\rho}_{n_i} \cdot \left\| \frac{dH_0}{dx} \right\| dx - \int \phi \cdot \bar{\rho}_\infty \cdot \left\| \frac{dH_0}{dx} \right\| dx \right|$$

and the fact that the first term in the right side goes to 0 by the unstable manifold theorem, while the second goes to 0 by (9.1).

The convergence (9.6) may be rewritten as

$$\int \phi \cdot \bar{\rho}_{n_i} d\bar{m}_{n_i} \xrightarrow{i \rightarrow \infty} \int \phi \cdot \bar{\rho}_\infty d\bar{m}_0.$$

Once we prove that

$$\int \phi \circ \bar{F}_{n_i} \cdot \bar{\rho}_{n_i} d\bar{m}_{n_i} \xrightarrow{i \rightarrow \infty} \int \phi \circ \bar{F}_0 \cdot \bar{\rho}_\infty d\bar{m}_0,$$

equality (9.5) and the uniqueness of the limit give the desired result.

**Claim.**  $\int \phi \circ \bar{F}_{n_i} \cdot \bar{\rho}_{n_i} d\bar{m}_{n_i}$  converges to  $\int \phi \circ \bar{F}_0 \cdot \bar{\rho}_\infty d\bar{m}_0$  when  $i \rightarrow \infty$ .

Given  $\varepsilon > 0$ , we want to find  $J \in \mathbb{N}$  such that for every  $i > J$

$$E_1 := \left| \int \phi \circ \bar{F}_{n_i}(x) \cdot \bar{\rho}_{n_i}(x) \cdot \left\| \frac{dH_{n_i}}{dx} \right\| dx - \int \phi \circ \bar{F}_0(x) \cdot \bar{\rho}_\infty(x) \cdot \left\| \frac{dH_0}{dx} \right\| dx \right| < \varepsilon.$$

Since  $\|\rho_{n_i}\|_\infty, \|\rho_\infty\|_\infty \leq M$  and  $\left\| \frac{dH_{n_i}}{dx} \right\|, \left\| \frac{dH_0}{dx} \right\| \leq \sqrt{1 + (10b)^2}$  we have

$$E_1 \leq \left| \int \phi \circ \bar{F}_{n_i} \cdot \bar{\rho}_{n_i} \cdot \left\| \frac{dH_{n_i}}{dx} \right\| \mathbf{1}_{\Omega_\infty^0 \cap \Omega_\infty^{n_i}} dx - \int \phi \circ \bar{F}_0 \cdot \bar{\rho}_\infty \cdot \left\| \frac{dH_0}{dx} \right\| \mathbf{1}_{\Omega_\infty^0 \cap \Omega_\infty^{n_i}} dx \right| + 2M\sqrt{1 + (10b)^2} \|\phi\|_\infty |\Omega_\infty^0 \Delta \Omega_\infty^{n_i}|$$

Taking

$$E_2 = \left| \int \phi \circ \bar{F}_{n_i} \cdot \bar{\rho}_{n_i} \cdot \left\| \frac{dH_{n_i}}{dx} \right\| \mathbf{1}_{\Omega_\infty^0 \cap \Omega_\infty^{n_i}} dx - \int \phi \circ \bar{F}_0 \cdot \bar{\rho}_\infty \cdot \left\| \frac{dH_0}{dx} \right\| \mathbf{1}_{\Omega_\infty^0 \cap \Omega_\infty^{n_i}} dx \right|$$

we have

$$E_1 \leq E_2 + 2M\sqrt{1 + (10b)^2} \|\phi\|_\infty |\Omega_\infty^0 \Delta \Omega_\infty^{n_i}|.$$

By Corollary 6.4, we may take  $J \in \mathbb{N}$  sufficiently large so that for  $i > J$

$$2M\sqrt{1 + (10b)^2} \|\phi\|_\infty |\Omega_\infty^0 \Delta \Omega_\infty^{n_i}| < \frac{\varepsilon}{2}.$$

Besides

$$E_2 \leq \left| \int \phi \circ \bar{F}_{n_i} \cdot \bar{\rho}_{n_i} \cdot \left[ \left\| \frac{dH_{n_i}}{dx} \right\| - \left\| \frac{dH_0}{dx} \right\| \right] \mathbf{1}_{\Omega_\infty^0 \cap \Omega_\infty^{n_i}} dx \right| + \left| \int \phi \circ \bar{F}_0 \cdot [\bar{\rho}_{n_i} - \bar{\rho}_\infty] \cdot \left\| \frac{dH_0}{dx} \right\| \mathbf{1}_{\Omega_\infty^0 \cap \Omega_\infty^{n_i}} dx \right| + \left| \int [\phi \circ \bar{F}_{n_i} - \phi \circ \bar{F}_0] \cdot \bar{\rho}_\infty \cdot \left\| \frac{dH_0}{dx} \right\| \mathbf{1}_{\Omega_\infty^0 \cap \Omega_\infty^{n_i}} dx \right|.$$

Denote by  $E_3, E_4$  and  $E_5$  respectively the terms in the last sum. Attending to the unstable manifold theorem and equation (9.1) it is clear that  $E_3$  and  $E_4$  can be made arbitrarily small. Noting that  $\sqrt{1 + (10b)^2} < 2$ , we have for any  $N$

$$E_5 \leq 2M\|\phi\|_\infty \sum_{l=N+1}^{\infty} (|\{R_{n_i} = l\}| + |\{R_0 = l\}|) + 2M\|\phi\|_\infty \sum_{l=1}^N |\{R_{n_i} = l\} \Delta \{R_0 = l\}| + 2M \sum_{l=1}^N \left| \int_{\{R_{n_i}=l\} \cap \{R_0=l\}} [\phi \circ \bar{F}_{n_i} - \phi \circ \bar{F}_0] \mathbf{1}_{\Omega_\infty^0 \cap \Omega_\infty^{n_i}} dx \right|.$$

Denote by  $E_6, E_7$  and  $E_8$  respectively the terms in the last sum. According to Proposition 4.1 we may choose  $N$  sufficiently large so that  $E_6$  is small enough. For this choice of

$N$  we appeal to Proposition 8.7 to find  $J \in \mathbb{N}$  sufficiently large so that  $E_7$  is also small enough. At this point we are left to deal with  $E_8$ . Let

$$E_8^l = \left| \int_{\{R_{n_i}=l\} \cap \{R_0=l\}} [\phi \circ \bar{F}_{n_i} - \phi \circ \bar{F}_0] \mathbf{1}_{\Omega_\infty^0 \cap \Omega_\infty^{n_i}} dx \right|.$$

The result will follow once we prove that  $E_8^l$  is arbitrarily small, which is achieved by showing that given  $\varsigma > 0$ , there exists  $J \in \mathbb{N}$  such that if  $i > J$ , then  $|\phi \circ \bar{f}_{n_i}^l - \phi \circ \bar{f}_0^l| < \varsigma$ .

Suppose that  $\varsigma$  is small enough for our purposes. Since  $\phi$  is continuous and  $\Omega_0$  is compact then there exists  $\eta > 0$  such that  $|\phi(x_1) - \phi(x_2)| < \varsigma$ , for every  $x_1, x_2$  belonging to any subset of  $\Omega_0$  with diameter less than  $\eta$ . We use Lemma 7.1 to choose  $N_2 \in \mathbb{N}$  sufficiently large so that if  $\omega$  is any connected component of  $H_0(\Omega_{N_2})$  then the maximum horizontal width of  $Q_{N_2}^2(\omega)$  is  $\eta/2$ . We take  $J \in \mathbb{N}$  sufficiently large so that  $\Omega_{N_2}^{n_i} = \Omega_{N_2}^0$  and by Lemma 7.2, for every connected component  $I$  of  $\Omega_{N_2}^0$  we have  $Q_{N_2}^1(H_{n_i}(I)) \subset Q_{N_2}^2(H_0(I))$ . We also want  $J \in \mathbb{N}$  large enough to guarantee (6.2) with  $b^{2N_2}$  instead of  $\varepsilon$  up to  $N$ .

Now, since  $f_0^l(H_0(x)) \in \Lambda_0$ , there exists a connected component  $I$  of  $\Omega_{N_2}^0$  such that  $f_0^l(H_0(x)) \in Q_{N_2}^1(H_0(I))$ . As  $|f_{n_i}^l(H_{n_i}(x)) - f_0^l(H_0(x))| < b^{2N_2}$ , then clearly  $f_{n_i}^l(H_{n_i}(x)) \in Q_{N_2}^2(H_0(I))$ . Moreover, since  $f_{n_i}^l(H_{n_i}(x)) \in \Lambda_{n_i}$  and we know that  $Q_{N_2}^2(H_0(I))$  intersects only one rectangle  $Q_{N_2}^1(H_{n_i}(L))$  with  $L$  representing any connected component of  $\Omega_{N_2}^{n_i}$ , then  $f_{n_i}^l(H_{n_i}(x)) \in Q_{N_2}^1(H_{n_i}(I))$ . Thus we have  $\bar{f}_0^l(H_0(x)) \in H_0(\Omega_0) \cap Q_{N_2}^2(H_0(I))$  and  $\bar{f}_{n_i}^l(H_{n_i}(x)) \in H_{n_i}(\Omega_0) \cap Q_{N_2}^2(H_0(I))$ . Finally, observe that  $H_0^{-1}(H_0(\Omega_0) \cap Q_{N_2}^2(H_0(I)))$  and  $H_{n_i}^{-1}(H_{n_i}(\Omega_0) \cap Q_{N_2}^2(H_0(I)))$  are both intervals containing  $I$  with length of at most  $\eta/2$  which means that  $|\phi(\bar{f}_0^l(H_0(x))) - \phi(\bar{f}_{n_i}^l(H_{n_i}(x)))| < \varsigma$ . See Figure 7.

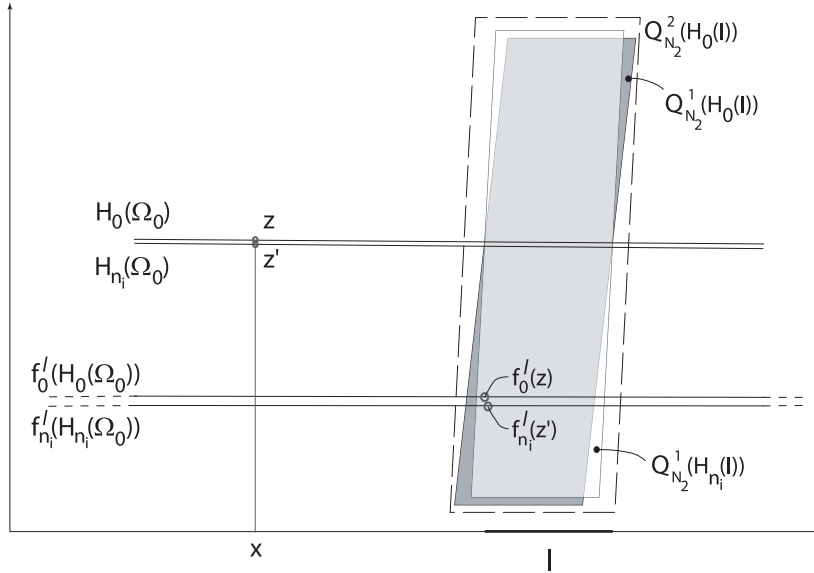

FIGURE 7

□

Then we lift the measure  $\bar{\nu}_{n_i}$  to an  $F_{n_i}$ -invariant measure  $\tilde{\nu}_{n_i}$  defined according to equation (9.3). Lemma 9.5 allows us to apply (9.3) to the measure  $\bar{\nu}_\infty$  and generate  $\tilde{\nu}_\infty$ . We observe that by Proposition 9.3 the measures  $\tilde{\nu}_\infty$  and  $\tilde{\nu}_{n_i}$  are SRB measures.

**9.3. Saturation and convergence of the measures.** Now we saturate the measures  $\tilde{\nu}_\infty$  and  $\tilde{\nu}_{n_i}$ . Let  $\tilde{\nu}$  be an SRB measure for  $f^R$  obtained from  $\bar{\nu} = \bar{\rho}d\bar{m}$  as in (9.3). We define the saturation of  $\tilde{\nu}$  by

$$\nu^* = \sum_{l=0}^{\infty} f_*^l(\tilde{\nu}|\{R > l\}) \quad (9.7)$$

It is well known that  $\nu^*$  is  $f$ -invariant and that the finiteness of  $\nu^*$  is equivalent to  $\int Rd\tilde{\nu} < \infty$ . Since  $\|\bar{\rho}\|_\infty < M$  and  $\bar{m}$  is equivalent to the 1-dimensional Lebesgue measure with uniformly bounded density, see [BY00, Section 5.2], then by Proposition 9.3(2) and Proposition 4.1 we easily get that  $\tilde{\nu}(\{R > l\}) \lesssim C_0\theta_0^l$  for some  $\theta_0 < 1$ . Since  $\int Rd\tilde{\nu} = \sum_{l=0}^{\infty} \tilde{\nu}(\{R > l\})$ , the finiteness of  $\nu^*$  is assured. Clearly, each  $f_*^l(\tilde{\nu}|\{R > l\})$  has absolutely continuous conditional measures on  $\{f^l\gamma^u\}$ , which are Pesin's unstable manifolds, and so  $\nu^*$  is an SRB measure.

Using (9.7) we define the saturations of the measures  $\tilde{\nu}_\infty$  and  $\tilde{\nu}_{n_i}$  to obtain  $\nu_\infty^*$  and  $\nu_{n_i}^*$  respectively. By construction, we know that  $\nu_\infty^*$  and  $\nu_{n_i}^*$  are SRB measures, which implies that  $\nu_\infty^* = \nu_0$  and  $\nu_{n_i}^* = \nu_{n_i}$ , by the uniqueness of the SRB measure.

To complete the argument we just need to the following result.

**Proposition 9.6.** *For every continuous  $g : \mathbb{R}^2 \rightarrow \mathbb{R}$ ,*

$$\int g d\nu_{n_i}^* \xrightarrow{i \rightarrow \infty} \int g d\nu_\infty^*.$$

*Proof.* First observe that there is a compact  $D \subset \mathbb{R}^2$  containing the attractors corresponding to the parameters  $(a_n, b_n)$  for all  $n \geq 0$ . As the supports of the measures  $\nu_\infty^*$  and  $\nu_{n_i}^*$  are contained in  $D$  we may assume henceforth that  $g$  is uniformly continuous and  $\|g\|_\infty < \infty$ .

Let  $\varepsilon$  be given. We look forward to find  $J \in \mathbb{N}$  sufficiently large so that for every  $i > J$

$$\left| \int g d\nu_{n_i}^* - \int g d\nu_\infty^* \right| < \varepsilon.$$

Recalling (9.7) we may write for any integer  $N_0$

$$\nu^* = \sum_{l=0}^{N_0-1} \nu^l + \eta$$

where  $\nu^l = f_*^l(\tilde{\nu}|\{R > l\})$  and  $\eta = \sum_{l \geq N_0} f_*^l(\tilde{\nu}|\{R > l\})$ . Since  $\tilde{\nu}(\{R > l\}) \lesssim C_0\theta_0^l$  for some  $\theta_0 < 1$ , we may choose  $N_0$  so that  $\eta(\mathbb{R}^2) < \varepsilon/3$ . We are reduced to find for every  $l < N_0$  a sufficiently large  $J$  so that for every  $i > J$

$$\left| \int (g \circ f_{n_i}^l) \mathbf{1}_{\{R_{n_i} > l\}} d\tilde{\nu}_{n_i} - \int (g \circ f_0^l) \mathbf{1}_{\{R_0 > l\}} d\tilde{\nu}_\infty \right| < \frac{\varepsilon}{3N_0}.$$

Fix  $l < N_0$  and take  $k \in \mathbb{N}$  large so that  $\text{var}(g(k)) < \frac{\varepsilon}{9N_0}$ . Attending to Proposition 9.3 (3) and its Remark 9.4, our problem will be solved if we exhibit  $J \in \mathbb{N}$  such that for every  $i > J$

$$E := \left| \int (g \circ f_{n_i}^l \circ F_{n_i}^k)^* (\mathbf{1}_{\{R_{n_i} > l\}} \circ F_{n_i}^k)^* d\bar{\nu}_{n_i} - \int (g \circ f_0^l \circ F_0^k)^* (\mathbf{1}_{\{R_0 > l\}} \circ F_0^k)^* d\tilde{\nu}_\infty \right| < \frac{\varepsilon}{9N_0}.$$

Defining

$$E_0 = \left| \int (g \circ f_{n_i}^l \circ F_{n_i}^k)^* (\mathbf{1}_{\{R_{n_i} > l\}} \circ F_{n_i}^k)^* \mathbf{1}_{\Omega_\infty^0 \cap \Omega_\infty^{n_i}} \bar{\rho}_{n_i} \left\| \frac{dH_{n_i}}{dx} \right\| dx \right. \\ \left. - \int (g \circ f_0^l \circ F_0^k)^* (\mathbf{1}_{\{R_0 > l\}} \circ F_0^k)^* \mathbf{1}_{\Omega_\infty^0 \cap \Omega_\infty^{n_i}} \bar{\rho}_\infty \left\| \frac{dH_0}{dx} \right\| dx \right|$$

we have  $E \leq E_0 + 4M\|g\|_\infty |\Omega_\infty^0 \Delta \Omega_\infty^{n_i}|$ . Using Corollary 6.4 we may find  $J \in \mathbb{N}$  so that for  $i > J$

$$4M\|g\|_\infty |\Omega_\infty^0 \Delta \Omega_\infty^{n_i}| < \frac{\varepsilon}{18N_0}.$$

Applying the triangular inequality we get

$$E_0 \leq M\|g\|_\infty \int \left| \left\| \frac{dH_{n_i}}{dx} \right\| - \left\| \frac{dH_0}{dx} \right\| \right| dx \\ + \left| \int (g \circ f_0^l \circ F_0^k)^* (\mathbf{1}_{\{R_0 > l\}} \circ F_0^k)^* \mathbf{1}_{\Omega_\infty^0 \cap \Omega_\infty^{n_i}} [\bar{\rho}_{n_i} - \bar{\rho}_\infty] \left\| \frac{dH_0}{dx} \right\| dx \right| \\ + 2M \int |(g \circ f_{n_i}^l \circ F_{n_i}^k)^* - (g \circ f_0^l \circ F_0^k)^*| \mathbf{1}_{\Omega_\infty^0 \cap \Omega_\infty^{n_i}} dx \\ + 2M\|g\|_\infty \int |(\mathbf{1}_{\{R_{n_i} > l\}} \circ F_{n_i}^k)^* - (\mathbf{1}_{\{R_0 > l\}} \circ F_0^k)^*| \mathbf{1}_{\Omega_\infty^0 \cap \Omega_\infty^{n_i}} dx.$$

By the unstable manifold theorem

$$\int \left| \left\| \frac{dH_{n_i}}{dx} \right\| - \left\| \frac{dH_0}{dx} \right\| \right| dx$$

can be made arbitrarily small by choosing a sufficiently large  $J \in \mathbb{N}$ . The term

$$\left| \int (g \circ f_0^l \circ F_0^k)^* (\mathbf{1}_{\{R_0 > l\}} \circ F_0^k)^* \mathbf{1}_{\Omega_\infty^0 \cap \Omega_\infty^{n_i}} [\bar{\rho}_{n_i} - \bar{\rho}_\infty] \left\| \frac{dH_0}{dx} \right\| dx \right|$$

can also be easily controlled attending to (9.1). The analysis of the remaining terms

$$\int |(g \circ f_{n_i}^l \circ F_{n_i}^k)^* - (g \circ f_0^l \circ F_0^k)^*| \mathbf{1}_{\Omega_\infty^0 \cap \Omega_\infty^{n_i}} dx$$

and

$$\int |(\mathbf{1}_{\{R_{n_i} > l\}} \circ F_{n_i}^k)^* - (\mathbf{1}_{\{R_0 > l\}} \circ F_0^k)^*| \mathbf{1}_{\Omega_\infty^0 \cap \Omega_\infty^{n_i}} dx$$

is left to Lemmas 9.8 and 9.9 below.  $\square$



In the proofs of Lemmas 9.8 and 9.9 we have to produce a suitable positive integer  $N$  so that returns that take longer than  $N$  iterations are negligible. The next lemma provides the tools for an adequate choice.

**Lemma 9.7.** *Given  $k, N \in \mathbb{N}$  we have*

$$|\{z \in H(\Omega_\infty) : \exists t \in \{1, \dots, k\} \text{ such that } R^t(z) > N\}| \leq k \frac{C_1^2}{|\Omega_0|} |\{R > N\}|.$$

*Proof.* We may write

$$\{z \in H(\Omega_\infty) : \exists t \in \{1, \dots, k\} \text{ such that } R^t(z) > N\} = \bigcup_{t=0}^{k-1} B_t,$$

where

$$B_t = \{z \in H(\Omega_\infty) : R(z) \leq N, \dots, R^t(z) \leq N, R^{t+1}(z) > N\}.$$

Let us show that  $|B_t| \leq \frac{C_1^2}{|\Omega_0|} |\{R > N\}|$  for every  $t \in \{0, \dots, k-1\}$ . Indeed, if  $R(z) \leq N, \dots, R^t(z) \leq N$  then there exist  $m_1, \dots, m_t \leq N$  and  $j_1 \leq v(m_1), \dots, j_t \leq v(m_t)$  such that  $z \in H(\Upsilon_{(m_1, j_1) \dots (m_t, j_t)})$ . Besides, for every  $l \in \{1, \dots, t\}$  there is  $\omega_{m_l, j_l} \in \tilde{\mathcal{P}}_{m_l-1}$  such that  $m_l$  is a regular return time for  $\omega_{m_l, j_l}$  and, according to Lemma 8.8,

$$H(\Upsilon_{(m_1, j_1) \dots (m_t, j_t)}) = \omega_{m_1, j_1} \cap \dots \cap f^{-(m_1 + \dots + m_{t-1})}(\omega_{m_t, j_t}) \cap f^{-(m_1 + \dots + m_t)}(H(\Omega_\infty)).$$

Let  $\omega = \omega_{m_1, j_1} \cap \dots \cap f^{-(m_1 + \dots + m_{t-1})}(\omega_{m_t, j_t})$ . Consider the set

$$\tilde{\omega} = \{z \in H(\Upsilon_{(m_1, j_1) \dots (m_t, j_t)}) : R^{t+1}(z) > N\} = \omega \cap f^{-(m_1 + \dots + m_t)}(\{R > N\}).$$

Using bounded distortion we obtain

$$\frac{|\tilde{\omega}|}{|\omega|} \leq C_1 \frac{|f^{m_1 + \dots + m_t}(\tilde{\omega})|}{|f^{m_1 + \dots + m_t}(\omega)|} \leq C_1 \frac{|\{R > N\}|}{2|\Omega_0|},$$

and

$$\frac{|H(\Upsilon_{(m_1, j_1) \dots (m_t, j_t)})|}{|\omega|} \geq C_1^{-1} \frac{|f^{m_1 + \dots + m_t}(H(\Upsilon_{(m_1, j_1) \dots (m_t, j_t)}))|}{|f^{m_1 + \dots + m_t}(\omega)|} \geq C_1^{-1} \frac{|\Omega_\infty|}{2},$$

from which we get

$$\frac{|\tilde{\omega}|}{|H(\Upsilon_{(m_1, j_1) \dots (m_t, j_t)})|} \leq \frac{C_1^2}{|\Omega_0|} \frac{|\{R > N\}|}{|\Omega_\infty|}.$$

Finally, we conclude that

$$|B_t| = \sum_{\substack{m_l \leq N \\ j_l \leq v(m_l) \\ l \in \{1, \dots, t\}}} |\tilde{\omega}| \leq \frac{C_1^2}{|\Omega_0|} \frac{|\{R > N\}|}{|\Omega_\infty|} \sum_{\substack{m_l \leq N \\ j_l \leq v(m_l) \\ l \in \{1, \dots, t\}}} |H(\Upsilon_{(m_1, j_1) \dots (m_t, j_t)})| \leq \frac{C_1^2}{|\Omega_0|} |\{R > N\}|.$$

□

**Lemma 9.8.** *Given  $l, k \in \mathbb{N}$  and  $\varepsilon > 0$  there is  $J \in \mathbb{N}$  such that for every  $i > J$*

$$\int |(g \circ f_{n_i}^l \circ F_{n_i}^k)^* - (g \circ f_0^l \circ F_0^k)^*| \mathbf{1}_{\Omega_\infty^0 \cap \Omega_\infty^{n_i}} dx < \varepsilon.$$

*Proof.* We split the argument into three steps:

- (1) We appeal to Lemma 9.7 to choose  $N_5 \in \mathbb{N}$  sufficiently large so that the set

$$L := \{x \in \Omega_\infty^0 \cap \Omega_\infty^{n_i} : \exists t \in \{1, \dots, k\} R_0^t(x) > N_5 \text{ or } R_{n_i}^t(x) > N_5\}$$

has sufficiently small mass.

- (2) We pick  $J \in \mathbb{N}$  large enough to guarantee that we are inside the neighborhood of  $(a_0, b_0)$  given by Proposition 8.9 when applied to  $N_5$  and a convenient fraction of  $\varepsilon$ . Namely, we have that for all  $m_1, \dots, m_k \leq N_5$  and all  $j_1 \leq v(m_1), \dots, j_k \leq v(m_k)$ , each set  $\Upsilon_{(m_1, j_1) \dots (m_k, j_k)}^0 \Delta \Upsilon_{(m_1, j_1) \dots (m_k, j_k)}^{n_i}$  has small Lebesgue measure.

- (3) Finally, in each set  $\Upsilon_{(m_1, j_1) \dots (m_k, j_k)}^0 \cap \Upsilon_{(m_1, j_1) \dots (m_k, j_k)}^{n_i}$  we control

$$|(g \circ f_{n_i}^l \circ F_{n_i}^k)^* - (g \circ f_0^l \circ F_0^k)^*|$$

for a better choice of  $J \in \mathbb{N}$ .

Step (1): From Lemma 9.7 we have  $|L| \leq \frac{2C_1^2}{|\Omega_0|} k C_0 \theta_0^{N_5}$ . So, we choose  $N_5$  large enough such that

$$2\|g\|_\infty \frac{2C_1^2}{|\Omega_0|} k C_0 \theta_0^{N_5} < \frac{\varepsilon}{3},$$

which implies that

$$\int_L |(g \circ f_{n_i}^l \circ F_{n_i}^k)^* - (g \circ f_0^l \circ F_0^k)^*| \mathbf{1}_{\Omega_\infty^0 \cap \Omega_\infty^{n_i}} dx < \frac{\varepsilon}{3}.$$

Step (2): By Proposition 8.9, we may choose  $J$  so that for every  $i > J$ ,  $m_1, \dots, m_k \leq N_5$  and  $j_1 \leq v(m_1), \dots, j_k \leq v(m_k)$  we have that

$$\left| \Upsilon_{(m_1, j_1) \dots (m_k, j_k)}^0 \Delta \Upsilon_{(m_1, j_1) \dots (m_k, j_k)}^{n_i} \right| < \frac{\varepsilon}{3} 5^{-k(N_5+2)} (2 \max\{1, \|g\|_\infty\})^{-1}.$$

Observe that by (8.1) we have that  $\sum_{m_1=1}^{N_5} v(m_1) \leq 5^{N_5+2}$  which means that the number of sets  $\Upsilon_{(m_1, j_1) \dots (m_k, j_k)}^0$  is less than  $5^{k(N_5+2)}$ . Consequently we have

$$\sum_{\substack{m_T \leq N_5 \\ j_T \leq v(m_T) \\ T = 1, \dots, k}} \int_{\Upsilon_{(m_1, j_1) \dots (m_k, j_k)}^0 \Delta \Upsilon_{(m_1, j_1) \dots (m_k, j_k)}^{n_i}} |(g \circ f_{n_i}^l \circ F_{n_i}^k)^* - (g \circ f_0^l \circ F_0^k)^*| \mathbf{1}_{\Omega_\infty^0 \cap \Omega_\infty^{n_i}} dx < \frac{\varepsilon}{3}.$$

Step (3): In each set  $\Upsilon_{(m_1, j_1) \dots (m_k, j_k)}^0 \cap \Upsilon_{(m_1, j_1) \dots (m_k, j_k)}^{n_i}$  we have that  $F_0^k = f_0^{m_1+\dots+m_k}$  and  $F_{n_i}^k = f_{n_i}^{m_1+\dots+m_k}$ . Since we are restricted to a compact set  $D$  and  $|Df| \leq 5$  for every  $f = f_{a,b}$  with  $(a, b) \in \mathbb{R}^2$ , then

- there exists  $\vartheta > 0$  such that  $|z - \zeta| < \vartheta \Rightarrow |g(z) - g(\zeta)| < \frac{\varepsilon}{3} 5^{-k(N_5+2)}$ ;

- there exists  $J_1$  such that for all  $i > J_1$  and  $z \in D$  we have

$$\max \{|f_0(z) - f_{n_i}(z)|, \dots, |f_0^{kN_5+l}(z) - f_{n_i}^{kN_5+l}(z)|\} < \frac{\vartheta}{2};$$

- there exists  $\eta > 0$  such that for all  $z, \zeta \in D$  and  $f = f_{a,b}$  with  $(a, b) \in \mathbb{R}^2$

$$|z - \zeta| < \eta \Rightarrow \max \{|f(z) - f(\zeta)|, \dots, |f^{kN_5+l}(z) - f^{kN_5+l}(\zeta)|\} < \frac{\vartheta}{2}.$$

Furthermore, according to Proposition 7.3,

- there is  $J_2$  such that for every  $i > J_2$  and  $x \in \Omega_\infty^0 \cap \Omega_\infty^{n_i}$  we have

$$\max_{t \in [-10b, 10b]} |\gamma_0^s(H_0(x))(t) - \gamma_{n_i}^s(H_{n_i}(x))(t)| < \eta.$$

Let  $i > \max\{J_1, J_2\}$ ,  $z \in \gamma_0^s(H_0(x))$  and  $t \in [-10b, 10b]$  be such that  $z = \gamma_0^s(H_0(x))(t)$ . Take  $\zeta = \gamma_{n_i}^s(H_{n_i}(x))(t)$ . Then, by the choice of  $J_2$ , it follows that  $|z - \zeta| < \eta$ . This together with the choices of  $\eta$  and  $J_1$  implies

$$\begin{aligned} |f_0^l \circ F_0^k(z) - f_{n_i}^l \circ F_{n_i}^k(\zeta)| &\leq \left| f_0^{m_1+\dots+m_k+l}(z) - f_0^{m_1+\dots+m_k+l}(\zeta) \right| \\ &\quad + \left| f_0^{m_1+\dots+m_k+l}(\zeta) - f_{n_i}^{m_1+\dots+m_k+l}(\zeta) \right| \\ &< \vartheta/2 + \vartheta/2 = \vartheta. \end{aligned}$$

Finally, the above considerations and the choice of  $\vartheta$  allow us to conclude that for every  $i > \max\{J_1, J_2\}$ ,  $x \in \Omega_\infty^0 \cap \Omega_\infty^{n_i}$  and  $z \in \gamma_0^s(H_0(x))$ , there exists  $\zeta \in \gamma_{n_i}^s(H_{n_i}(x))$  such that

$$|g(f_{n_i}^l \circ F_{n_i}^k(\zeta)) - g(f_0^l \circ F_0^k(z))| < \frac{\varepsilon}{3} 5^{-k(N_5+2)}. \quad (9.8)$$

Attending to (9.2), (9.8) and the fact that we can interchange the roles of  $z$  and  $\zeta$  in the latter, we obtain that for every  $i > \max\{J_1, J_2\}$

$$|(g \circ f_{n_i}^l \circ F_{n_i}^k)^* - (g \circ f_0^l \circ F_0^k)^*| < \frac{\varepsilon}{3} 5^{-k(N_5+2)},$$

from where we deduce that

$$\sum_{\substack{m_T \leq N_5 \\ j_T \leq v(m_T) \\ T \in \{1, \dots, k\}}} \int_{\Upsilon_{(m_1, j_1) \dots (m_k, j_k)}^0 \cap \Upsilon_{(m_1, j_1) \dots (m_k, j_k)}^{n_i}} |(g \circ f_{n_i}^l \circ F_{n_i}^k)^* - (g \circ f_0^l \circ F_0^k)^*| \mathbf{1}_{\Omega_\infty^0 \cap \Omega_\infty^{n_i}} dx < \frac{\varepsilon}{3}.$$

□

**Lemma 9.9.** *Given  $l, k \in \mathbb{N}$  and  $\varepsilon > 0$  there exists  $J \in \mathbb{N}$  such that for every  $i > J$*

$$\int |(\mathbf{1}_{\{R_{n_i} > l\}} \circ F_{n_i}^k)^* - (\mathbf{1}_{\{R_0 > l\}} \circ F_0^k)^*| \mathbf{1}_{\Omega_\infty^0 \cap \Omega_\infty^{n_i}} dx < \varepsilon.$$

*Proof.* As in the proof of Lemma 9.8, we divide the argument into three steps.

(1) The condition on  $N_5$ : Consider the set

$$L_1 = \{x \in \Omega_\infty^0 \cap \Omega_\infty^{n_i} : \exists t \in \{1, \dots, k+1\} \text{ such that } R_0^t(x) > N_5 \text{ or } R_{n_i}^t(x) > N_5\}.$$

From Lemma 9.7 we have  $|L_1| \leq \frac{2C_1^2}{|\Omega_0|}(k+1)C_0\theta_0^{N_5}$ . So we choose  $N_5$  large enough so that

$$\frac{4C_1^2}{|\Omega_0|}(k+1)C_0\theta_0^{N_5} < \frac{\varepsilon}{3},$$

which implies that

$$\int_{L_1} |(\mathbf{1}_{\{R_{n_i} > l\}} \circ F_{n_i}^k)^* - (\mathbf{1}_{\{R_0 > l\}} \circ F_0^k)^*| \mathbf{1}_{\Omega_\infty^0 \cap \Omega_\infty^{n_i}} dx < \frac{\varepsilon}{3}.$$

(2) Let us choose  $J$  large enough so that, by Proposition 8.9, for all  $m_1, \dots, m_{k+1} \leq N_5$  and  $j_1 \leq v(m_1), \dots, j_{k+1} \leq v(m_{k+1})$  we get

$$\left| \Upsilon_{(m_1, j_1) \dots (m_{k+1}, j_{k+1})}^0 \Delta \Upsilon_{(m_1, j_1) \dots (m_{k+1}, j_{k+1})}^{n_i} \right| < \frac{\varepsilon}{3} 5^{-(k+1)(N_5+2)} 2^{-1}.$$

Observe that by (8.1) we have  $\sum_{m_1=1}^{N_5} v(m_1) \leq 5^{N_5+2}$  which means that the number of sets  $\Upsilon_{(m_1, j_1) \dots (m_{k+1}, j_{k+1})}^0$  is less than  $5^{(k+1)(N_5+2)}$ . Let

$$L_2 = \Upsilon_{(m_1, j_1) \dots (m_{k+1}, j_{k+1})}^0 \Delta \Upsilon_{(m_1, j_1) \dots (m_{k+1}, j_{k+1})}^{n_i}$$

and observe that

$$\sum_{\substack{m_T \leq N_5 \\ j_T \leq v(m_T) \\ T \in \{1, \dots, k+1\}}} \int_{L_2} |(\mathbf{1}_{\{R_{n_i} > l\}} \circ F_{n_i}^k)^* - (\mathbf{1}_{\{R_0 > l\}} \circ F_0^k)^*| \mathbf{1}_{\Omega_\infty^0 \cap \Omega_\infty^{n_i}} dx < \frac{\varepsilon}{3}.$$

(3) At last, notice that in each set  $\Upsilon_{(m_1, j_1) \dots (m_{k+1}, j_{k+1})}^0 \cap \Upsilon_{(m_1, j_1) \dots (m_{k+1}, j_{k+1})}^{n_i}$  we have

$$|(\mathbf{1}_{\{R_{n_i} > l\}} \circ F_{n_i}^k)^* - (\mathbf{1}_{\{R_0 > l\}} \circ F_0^k)^*| = 0,$$

which gives the result.  $\square$

## REFERENCES

- [AV02] J. F. Alves and M. Viana, *Statistical stability for robust classes of maps with non-uniform expansion*, Ergd. Th. & Dynam. Sys. **22** (2002), 1–32.
- [BC85] M. Benedicks and L. Carleson, *On iterations of  $1-ax^2$  on  $(-1, 1)$* , Ann. Math. **122** (1985), 1–25.
- [BC91] M. Benedicks and L. Carleson, *The dynamics of the Hénon map*, Ann. Math. **133** (1991), 73–169.
- [BV06] M. Benedicks and M. Viana, *Random perturbations and statistical properties of Hénon-like maps*, Ann. Inst. Henri Poincaré, Anal. NonLinéaire, **23** (2006), no. 5, 713–752.
- [BV01] M. Benedicks and M. Viana, *Solution of the basin problem for Hénon-like attractors*, Invent. Math. **143** (2001), 375–434.
- [BY93] M. Benedicks and L. Young, *Sinai-Bowen-Ruelle measures for certain Hénon maps*, Invent. Math. **112** (1993), 541–576.
- [BY00] M. Benedicks and L. Young, *Markov extensions and decay of correlations for certain Hénon maps*, Astérisque **261** (2000), 13–56.
- [BDV05] C. Bonatti, L. J. Díaz, and M. Viana, *Dynamics Beyond Uniform Hiperbolicity*, Springer-Verlag (2005).
- [Bo75] R. Bowen, *Equilibrium States and Ergodic Theory of Anosov Diffeomorphisms*, *Lecture Notes in Mathematics*, volume 470, Springer-Verlag (1975).

- [CE80a] P. Collet and J. Eckmann, *On the abundance of aperiodic behavior for maps on the interval*, Comm. Math. Phys. **73** (1980), 115–160.
- [CE80b] P. Collet and J. P. Eckmann, *On the abundance of aperiodic behavior for maps on the interval*, Bull. Amer. Math. Soc. **3** (1980), no. 1, 699–700.
- [CE83] P. Collet and J. P. Eckmann, *Positive Lyapunov exponents and absolute continuity for maps of the interval*, Ergd. Th. & Dynam. Sys. **3** (1983), 13–46.
- [Fr05] J. M. Freitas, *Continuity of SRB measure and entropy for Benedicks-Carleson quadratic maps*, Nonlinearity **18** (2005), 831–854.
- [He76] M. Hénon, *A two dimensional mapping with a strange attractor*, Comm. Math. Phys. **50** (1976), 69–77.
- [HS74] M. Hirsch and S. Smale, *Differential Equations, Dynamical Systems and Linear Algebra*, Academic Press Inc. (1974).
- [Ja81] M. Jakobson, *Absolutely continuous invariant measures for one parameter families of one-dimensional maps*, Comm. Math. Phys. **81** (1981), 39–88.
- [LV03] S. Luzzatto and M. Viana, *Parameter exclusions in Hénon-like systems*, Russian Math. Surveys **58** (2003), 1053–1092.
- [MV93] L. Mora and M. Viana, *Abundance of strange attractors*, Acta Math. **171** (1993), 1–71.
- [Ne74] S. Newhouse, *Diffeomorphisms with infinitely many sinks*, Topology **13** (1974), 9–18.
- [Ne79] S. Newhouse, *The abundance of wild hyperbolic sets and non-smooth stable sets for diffeomorphisms*, Publ. Math., Inst. Hautes Étud. Sci. **50** (1979), 101–152.
- [Pe78] J. B. Pesin, *Families of invariant manifolds corresponding to nonzero characteristic exponents*, Math. USSR Izv. **10** (1978), 1261–1305.
- [Ru79] D. Ruelle, *Ergodic theory of differentiable dynamical systems*, Publ. Math., Inst. Hautes Étud. Sci. **50** (1979), 27–58.
- [RS97] M. Rychlik and E. Sorets, *Regularity and other properties of absolutely continuous invariant measures for the quadratic family*, Comm. Math. Phys. **150** (1992), no. 2, 217–236.
- [Th01] H. Thunberg, *Unfolding of chaotic unimodal maps and the parameter dependence of natural measures*, Nonlinearity **14** (2001), no. 2, 323–337.
- [Ts96] M. Tsujii, *On continuity of Bowen-Ruelle-Sinai measures in families of one dimensional maps*, Comm. Math. Phys. **177** (1996), no. 1, 1–11.
- [Ur95] R. Ures, *On the approximation of Hénon-like attractors by homoclinic tangencies*, Ergd. Th. & Dynam. Sys. **15** (1995), 1223–1229.
- [Ur96] R. Ures, *Hénon attractors: SRB measures and Dirac measures for sinks*, in 1st International Conference on Dynamical Systems, Montevideo, Uruguay, 1995 - a tribute to Ricardo Mañé, *Pitman Res. Notes Math. Ser.*, volume 362, Harlow: Longman, 214–219.
- [WY01] Q. Wang and L. S. Young, *Strange Attractors with One Direction of Instability*, Comm. Math. Phys. **218** (2001), 1–97.
- [Yo98] L. S. Young, *Statistical properties of dynamical systems with some hyperbolicity*, Ann. Math. **147** (1998), 585–650.

JOSÉ F. ALVES, CENTRO DE MATEMÁTICA DA UNIVERSIDADE DO PORTO, RUA DO CAMPO ALEGRE 687, 4169-007 PORTO, PORTUGAL

*E-mail address:* `jfalves@fc.up.pt`

*URL:* `http://www.fc.up.pt/cmup/jfalves`

MARIA CARVALHO, CENTRO DE MATEMÁTICA DA UNIVERSIDADE DO PORTO, RUA DO CAMPO ALEGRE 687, 4169-007 PORTO, PORTUGAL

*E-mail address:* `mpcarval@fc.up.pt`

JORGE M. FREITAS, CENTRO DE MATEMÁTICA DA UNIVERSIDADE DO PORTO, RUA DO CAMPO ALEGRE 687, 4169-007 PORTO, PORTUGAL

*E-mail address:* `jmfreita@fc.up.pt`

*URL:* `http://www.fc.up.pt/pessoas/jmfreita`